

Jammin Mini CRT.5 Set-Up Sheet

Date: 3-4-07

Driver: Jammin Jay

Track: Red Deer / Canada

Air Temp: 60

Surface Dsc. Indoor Clay

Avg. Lap Time: "

Front Suspension

Shock Spring: Stock grey

Shock Piston: / /

Shock Oil wt: 60wt

Shock Length: mm
(Center to Center)

Toe-IN: mm

Toe-Out: 2Deg

Front Ride Height: Arms level

Sway Bar: None

Camber: Neg: 2Deg

Pos: mm

Caster Angle:

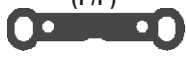

(F/F)

F/F	<input type="radio"/>	<input type="radio"/>	<input type="radio"/>	<input type="radio"/>
F/R	<input type="radio"/>	<input type="radio"/>	<input type="radio"/>	<input type="radio"/>
(F/R)	<input type="radio"/>	<input checked="" type="radio"/>	<input type="radio"/>	<input type="radio"/>
	<input type="radio"/>	<input type="radio"/>	<input type="radio"/>	<input type="radio"/>
	22	21	20	
	23	22	21	
	24	23	22	



(F/R)

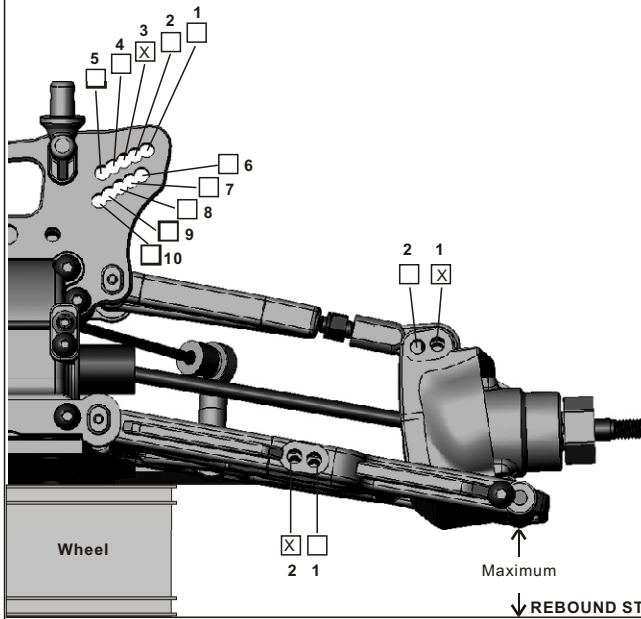

Steering Ackerman Location

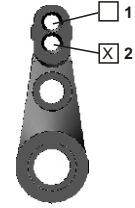

Front Sway Bar Preload

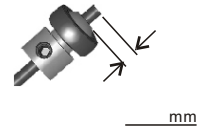

Notes: _____

Rear Suspension

Shock Spring: Stock Grey

Shock Piston: / /

Shock Oil wt: 35 wt

Shock Length: mm
(Center to Center)

Rear Ride Height: Arms slightly above level

Sway Bar: Stock

Camber: Neg: 2Deg

Pos: mm

Anti-Squat Plate



R/F

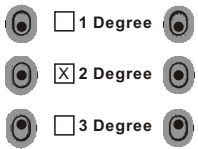

(Right = Left)

Rear Toe-In Plate



R/R

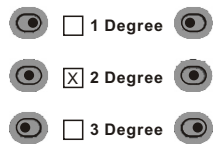

(Right = Left)

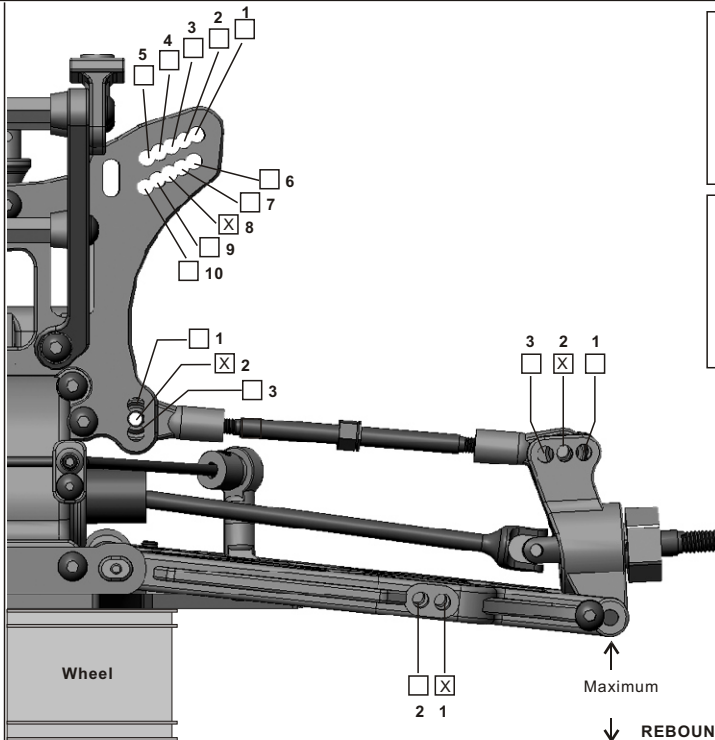

Front Sway Bar Preload

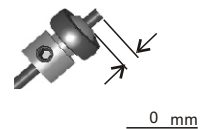

Wing Position



Wheelbase

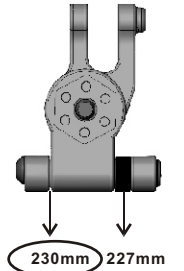

Differential

Front Type Std Oil 1000

Center Type Std Oil 1000

Rear Type Std Oil 500

Tires

Front Type: Brand _____ Compound _____ Foam: _____

Rear Type: Brand _____ Compound _____ Foam: _____

Note: _____

Engine

Type: Jammin 12

Head Clearance Std

Pipe: Jammin CRT.5

Fuel: Byron % 30 Plug Std

Needle (Top) _____ (Bottom) _____

CLUTCH

Shoe Brand Stock Compound Stock

Spring Brand Stock Tension Stock

Gearing: T T TO T

Note: _____