

# SCRT10 Set-Up Sheet

Date: \_\_\_\_\_

Driver: \_\_\_\_\_

Track: \_\_\_\_\_ / \_\_\_\_\_

Air Temp: \_\_\_\_\_ 80F \_\_\_\_\_

Surface Dsc. \_\_\_\_\_ WATERED & DRY \_\_\_\_\_

Avg. Lap Time: \_\_\_\_\_ "

## Front Suspension

Shock Spring: \_\_\_\_\_ Gray \_\_\_\_\_

Shock Piston:   /   /

Shock Oil wt: \_\_\_\_\_

Shock Length: \_\_\_\_\_ mm  
(Center to Center)

Toe-IN: \_\_\_\_\_

Toe-Out: \_\_\_\_\_

Front Ride Height: \_\_\_\_\_

Sway Bar: \_\_\_\_\_ None \_\_\_\_\_

Camber: Neg: \_\_\_\_\_

Pos: \_\_\_\_\_

Caster Angle:



(F/F)

F/F \ F/R	<input type="checkbox"/>	<input type="checkbox"/>	<input type="checkbox"/>
(F/F)	<input type="checkbox"/>	22	21
(F/R)	<input type="checkbox"/>	23	22
	<input type="checkbox"/>	24	23



(F/R)

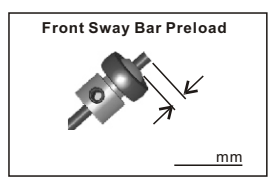
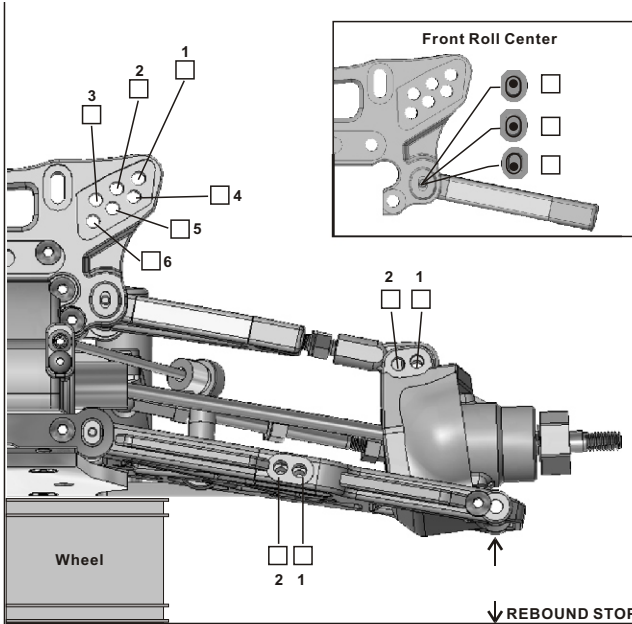

Notes: \_\_\_\_\_

## Rear Suspension

Shock Spring: \_\_\_\_\_ Gray \_\_\_\_\_

Shock Piston:   /   /

Shock Oil wt: \_\_\_\_\_

Shock Length: \_\_\_\_\_ mm  
(Center to Center)

Rear Ride Height: \_\_\_\_\_ mm

Sway Bar: \_\_\_\_\_ None \_\_\_\_\_

Camber: Neg: \_\_\_\_\_

Pos: \_\_\_\_\_

Anti-Squat Plate



R/F

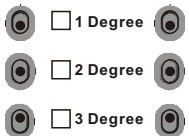

(Right = Left)

Rear Toe-In Plate



R/R

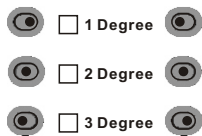

(Right = Left)

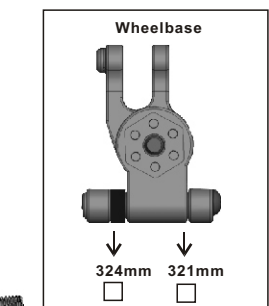
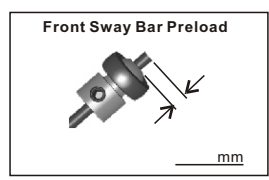
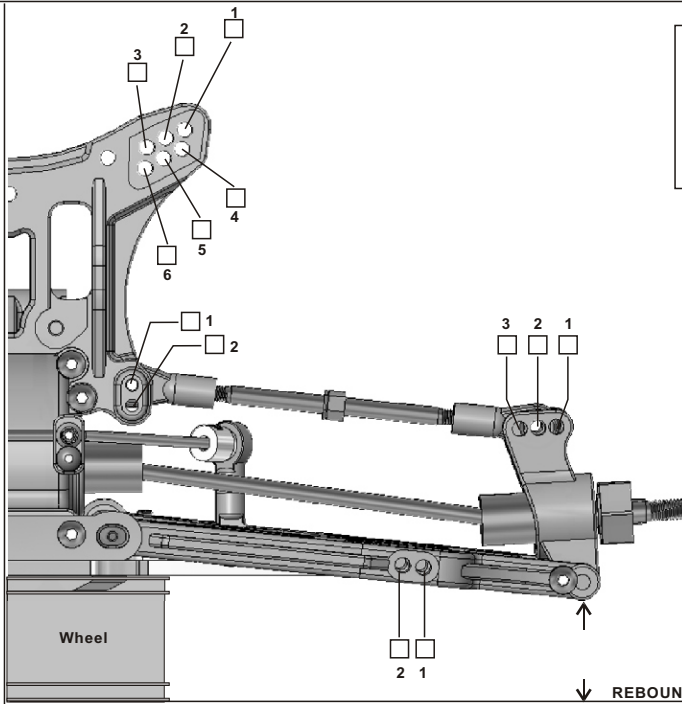

## Differential

Oil Type  SBCicon  Grease

Front: STD-5K  \_\_\_\_\_ K

Center: STD-7K  \_\_\_\_\_ K

Rear: STD-1K  \_\_\_\_\_ K

## Tires

Front: STD

Rear: STD

Foam: STD

Others: Brand: \_\_\_\_\_

Type: \_\_\_\_\_

Insert: Foam  \_\_\_\_\_

## ELECTRIC MOTOR

Type: Brush  Brushless

Turn: \_\_\_\_\_ Turn: \_\_\_\_\_

RPM: \_\_\_\_\_ KV: \_\_\_\_\_

Brand: \_\_\_\_\_

## ELECTRIC SPEED CONTROLLER

Brand: \_\_\_\_\_

Type: \_\_\_\_\_

## GEAR

Super Gear: 46 T

Motor Gear: \_\_\_\_\_ T

Gear Brand: STD  Other: \_\_\_\_\_