

# SCRT-10 Set-Up Sheet

Date: 1/2010

Driver: Chad Bradley

Track: All / \_\_\_\_\_

Air Temp: 60 F

Surface Desc. WATERED & DRY

Avg. Lap Time: \_\_\_\_\_ "

## Front Suspension

Shock Spring: \_\_\_\_\_ White

Shock Piston:   /   /

Shock Oil wt 50 Losi

Shock Length: \_\_\_\_\_ mm  
(Center to Center)

Toe-IN: \_\_\_\_\_

Toe-Out: 2

Front Ride Height: Arms slightly below level

Sway Bar: \_\_\_\_\_ Std \_\_\_\_\_

Camber: Neg: 2

Pos: \_\_\_\_\_

Caster Angle:



(F/F)

F/F \ F/R	<input type="radio"/>	<input type="radio"/>	<input type="radio"/>
F/R	22	21	20
F/R	<input type="radio"/>	<input checked="" type="radio"/>	<input type="radio"/>
F/R	23	22	21
F/R	<input type="radio"/>	<input type="radio"/>	<input type="radio"/>
F/R	24	23	22



(F/R)

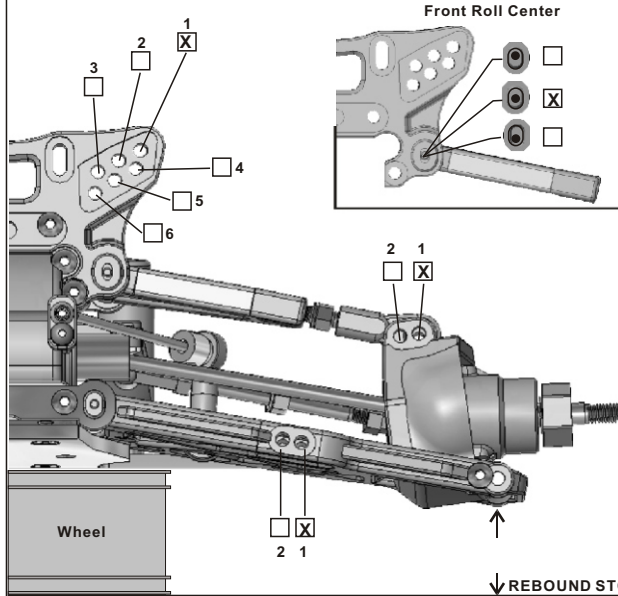

Front Roll Center

Steering Ackerman Location

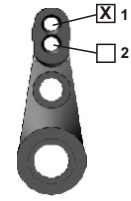

Front Sway Bar Preload

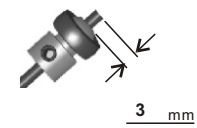

Notes: Full Travel Front & Rear

## Rear Suspension

Shock Spring: \_\_\_\_\_ White

Shock Piston:   /   /

Shock Oil wt 50 Losi

Shock Length: \_\_\_\_\_ mm  
(Center to Center)

Rear Ride Height: Arms slightly below level

Sway Bar: \_\_\_\_\_ Std \_\_\_\_\_

Camber: Neg: 2

Pos: \_\_\_\_\_

Anti-Squat Plate



R/F

1 Degree   
 2 Degree   
 3 Degree   
(Rig ht = L eft)

Rear Toe-In Plate



R/R

1 Degree   
 2 Degree   
 3 Degree   
(Rig ht = L eft)

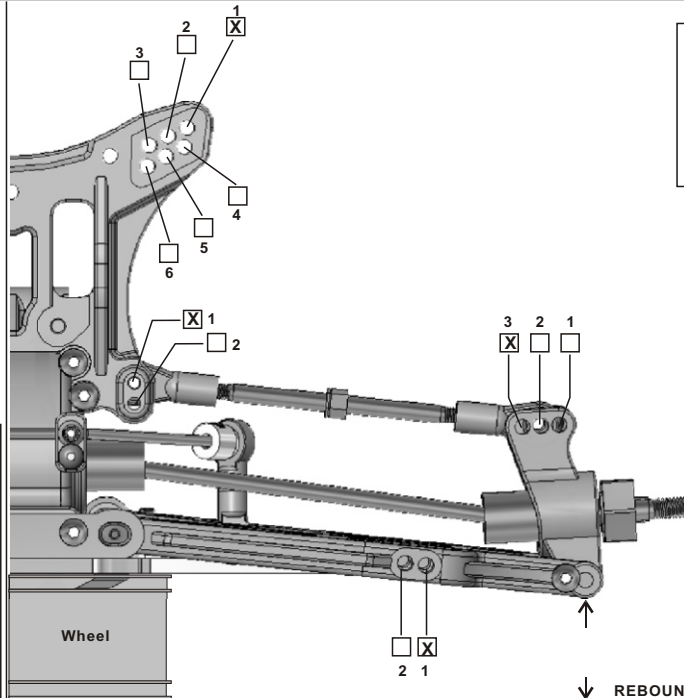

Front Sway Bar Preload

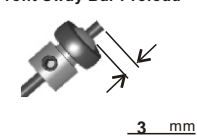

Wheelbase

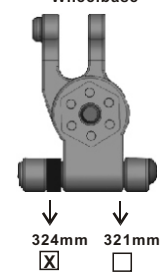

## Differential

Oil Type Silicon  Grease

Front: STD-5K  3 K

Center: STD-7K  3 K

Rear: STD-1K  1 K

## Tires

Front: STD

Rear: STD

Foam: STD

Others: Brand: \_\_\_\_\_

Type: \_\_\_\_\_

Insert: Foam  \_\_\_\_\_

## ELECTRIC MOTOR

Type: Brush  Brushless

Turn: \_\_\_\_\_ Turn: \_\_\_\_\_

RPM: \_\_\_\_\_ KV: \_\_\_\_\_

Brand: Novak 4.5 HV

## ELECTRIC SPEED CONTROLLER

Brand: Novak

Type: Brushless Havoc Pro

## GEAR

Super Gear: 46 T

Motor Gear: 13 or 14 T

Gear Brand: STD  Other: \_\_\_\_\_

Short track = 13t or Long track = \_\_\_\_\_