

Jammin X1-CRT Set-Up Sheet

Track Size	Traction	Surface
<input checked="" type="checkbox"/> Open	<input type="checkbox"/> High	<input type="checkbox"/> Smooth
<input type="checkbox"/> Medium	<input checked="" type="checkbox"/> Medium	<input type="checkbox"/> Medium
<input type="checkbox"/> Tight	<input type="checkbox"/> Low	<input checked="" type="checkbox"/> Bumpy

Driver: Taylor James

Track: The Silver State Air Temp: 75F

Note: Track surface extremely bumpy

Front Suspension

Shock Spring: Blue

Shock Piston: Standard Drilled

Shock Oil wt: 60 Assoc

Shock Length
(Bottom of body to shock end) N/A

Toe-IN:

Toe-Out: 2-3 Degree

Front Ride Height: Arms Slightly above level

Sway Bar: 2mm 2.3mm 2.5mm

Camber: Neg: 2 Degrees
 Pos: _____

Caster Block: A/A B/B

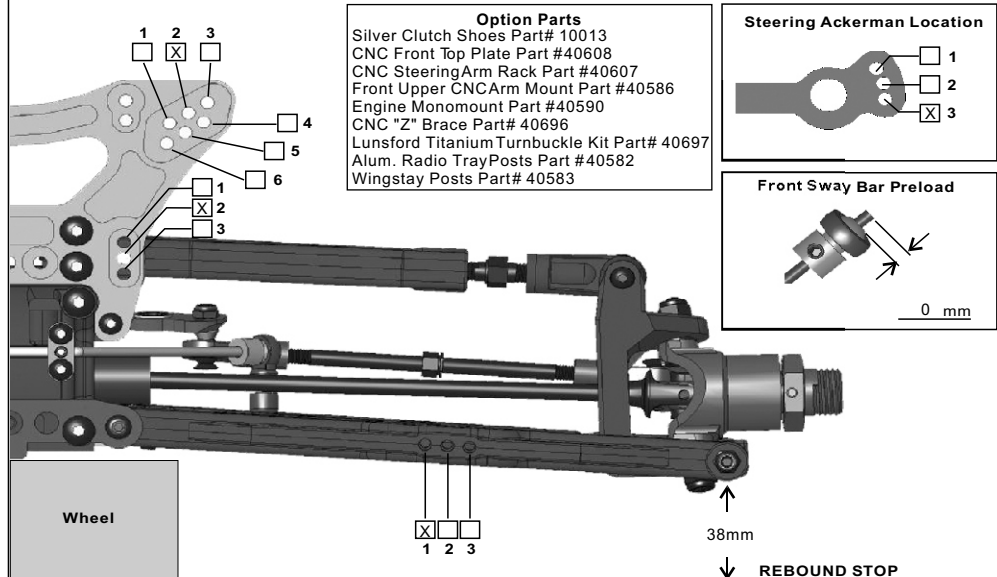
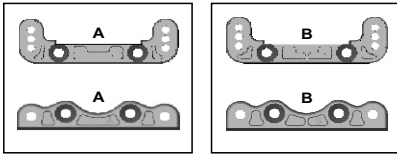

Option Parts
 Silver Clutch Shoes Part# 10013
 CNC Front Top Plate Part #40608
 CNC Steering Arm Rack Part #40607
 Front Upper CNC Arm Mount Part #40586
 Engine Monomount Part #40590
 CNC "Z" Brace Part# 40696
 Lunsford Titanium Turnbuckle Kit Part# 40697
 Alum. Radio Tray Posts Part #40582
 Wingstay Posts Part# 40583

Notes: _____

Rear Suspension

Shock Spring: Blue

Shock Piston: Standard Drilled

Shock Oil wt: 50 Assoc.

Shock Length
(Bottom of body to shock end) N/A

Rear Ride Height: Slightly above arms level

Sway Bar: 2.3mm 2.5mm 2.8mm
 None

Camber: Neg: 2 Degrees
 Pos: _____

Rear Hub/Wheelbase: Forward Middle
 Back Reversed

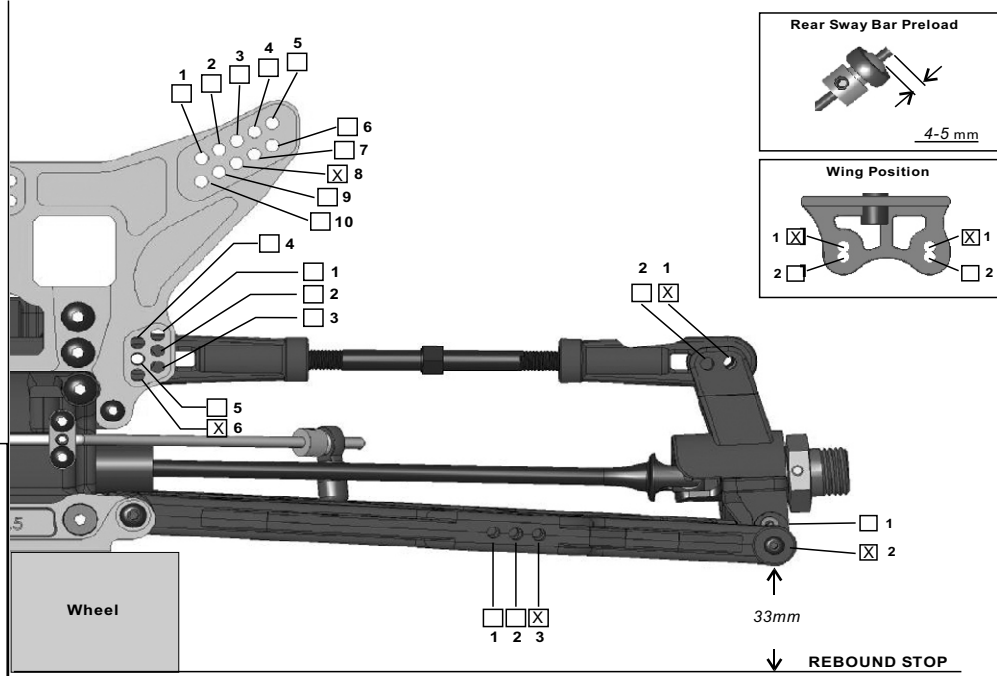
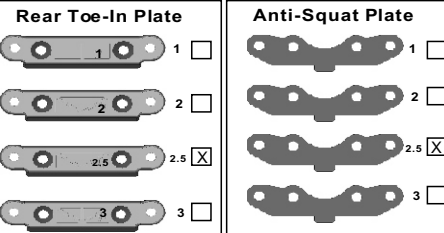

Differential

Front Type: STD Torsen Oil 7K

Center Type: STD Torsen Oil 20K

Rear Type: STD Torsen Oil 3K

Tires

Front Type: PL Crime Bowtie MT Compound STD Foam: White

Rear Type: PL Crime Bowtie MT Compound STD Foam: White

Note: Tire mounted on inside of inner bead and rim trimmed

Engine

Type: OS V Spec .21

Head Clearance STD Port: STD

Pipe: Jammin JP-1

Fuel: O'Donnell 30%

Plug O'Donnell 97 Turbo Normal

CLUTCH

Shoe Brand: Jammin Compound: Alum: Silver Blue Red 3 Shoes

Spring Brand: Jammin Tension: Gold Heavy 1.1mm

Gearing: 13T 14T TO 62T Other T

Note: _____