

Jammin X1-CRT Set-Up Sheet

Driver: Chad Bradley

Track: Sun Valley Raceway RC Pro Finals

Air Temp: 65F

Track Size	Traction	Surface
<input checked="" type="checkbox"/> open	<input type="checkbox"/> High	<input checked="" type="checkbox"/> Smooth
<input type="checkbox"/> Medium	<input checked="" type="checkbox"/> Medium	<input type="checkbox"/> Medium
<input type="checkbox"/> Tight	<input type="checkbox"/> Low	<input type="checkbox"/> Bumpy

Front Suspension

Shock Spring: Blue

Shock Piston: Standard Drilled

Shock Oil wt: 50 Losi

Shock Length
(Bottom of body to shock end) 26mm

Toe-IN:

Toe-Out: 1 Degree

Front Ride Height: Arms slightly below level

Sway Bar: 2mm 2.3mm 2.5mm

Camber: Neg: 2 Degrees
 Pos:

Caster Block: A/A B/B

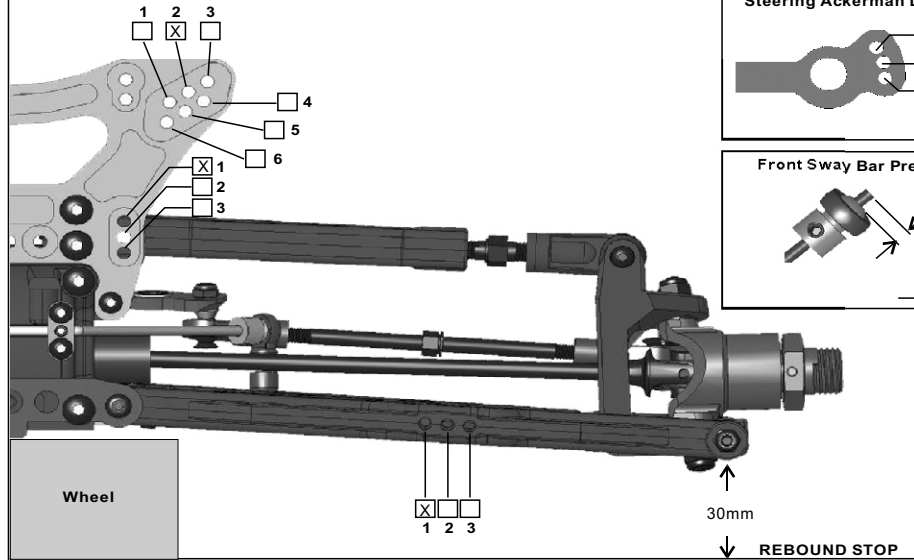
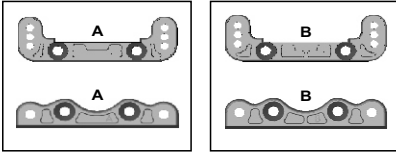

Steering Ackerman Location



Front Sway Bar Preload

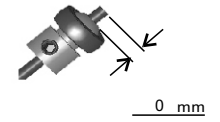

Notes: 1/2 Oz. Weight added behind tower

Rear Suspension

Shock Spring: Blue

Shock Piston: Standard Drilled

Shock Oil wt: 50 Losi

Shock Length
(Bottom of body to shock end) 39mm

Rear Ride Height: Arms level

Sway Bar: 2.3mm 2.5mm 2.8mm
 None

Camber: Neg: 3 Degrees
 Pos:

Rear Hub/Wheelbase: Forward Middle
 Back

Rear Toe-In Plate

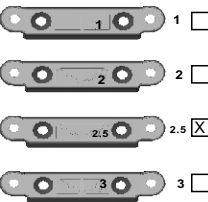

Anti-Squat Plate

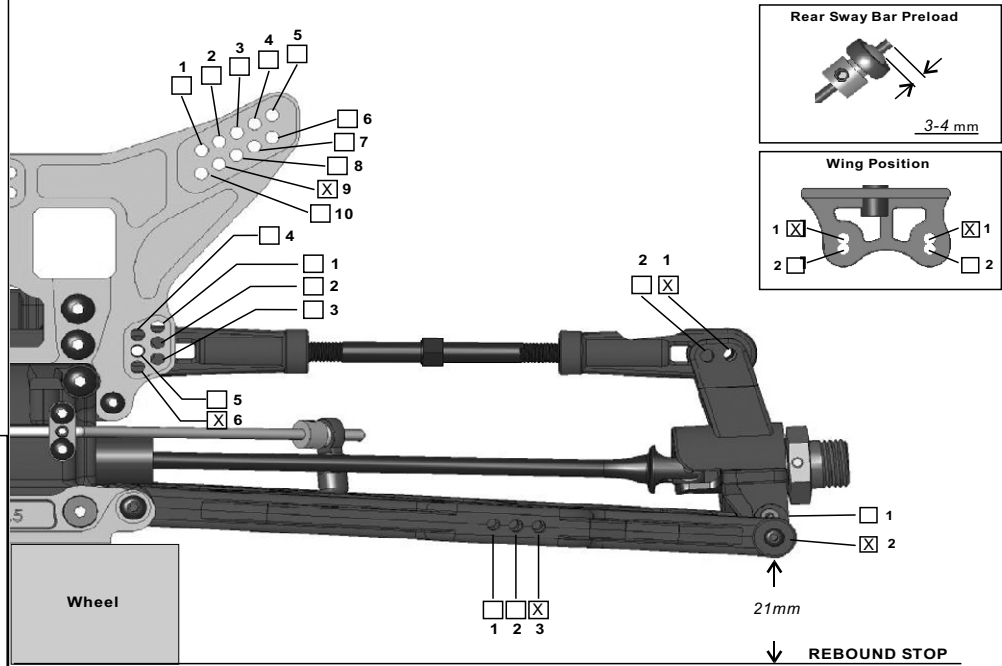
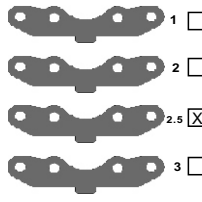

Rear Sway Bar Preload

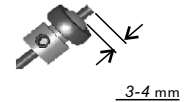

Wing Position

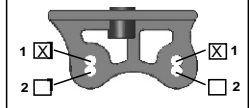

Differential

Front Type: STD Torsen Oil 7K

Center Type: STD Torsen Oil 20K

Rear Type: STD Torsen Oil 2K

Tires

Front Type: PL Crime Fighter MT Compound STD Foam: STD

Rear Type: PL Crime Fighter MT Compound STD Foam: STD

Note: Tire mounted on inside of inner bead and rim trimmed

Engine

Type: OS VSpec .21

Head Clearance STD Port: STD

Pipe: Jammin JP-1

Fuel: Byron RACE 30%

Plug A3 Turbo Normal

CLUTCH

Shoe Brand: Jammin Compound: ALUM: Blue Red

Spring Brand: Jammin Tension: Gold Heavy 1.1mm

Gearing: 13T 14T TO 62T Other T

Note: Prep clutch as per Tips on web site

Clutch Shoes:

2 Shoes

3 Shoes

4 Shoes