

Jammin X1-CRT Set-Up Sheet

Driver: Chad Bradley

Track: The Silver State (Qualifying set-up)

Air Temp: 75F

Track Size	Traction	Surface
<input checked="" type="checkbox"/> open	<input type="checkbox"/> High	<input type="checkbox"/> Smooth
<input type="checkbox"/> Medium	<input checked="" type="checkbox"/> Medium	<input checked="" type="checkbox"/> Medium
<input type="checkbox"/> Tight	<input type="checkbox"/> Low	<input checked="" type="checkbox"/> Bumpy

Front Suspension

Shock Spring: Blue

Shock Piston: Standard Drilled

Shock Oil wt: 60Losi

Shock Length (Bottom of body to shock end) N/A

Toe-IN:

Toe-Out: 2-3 Degree

Front Ride Height: Arms level

Sway Bar: 2mm 2.3mm 2.5mm

Camber: Neg: 2 Degrees

Pos:

Caster Block: A/A B/B

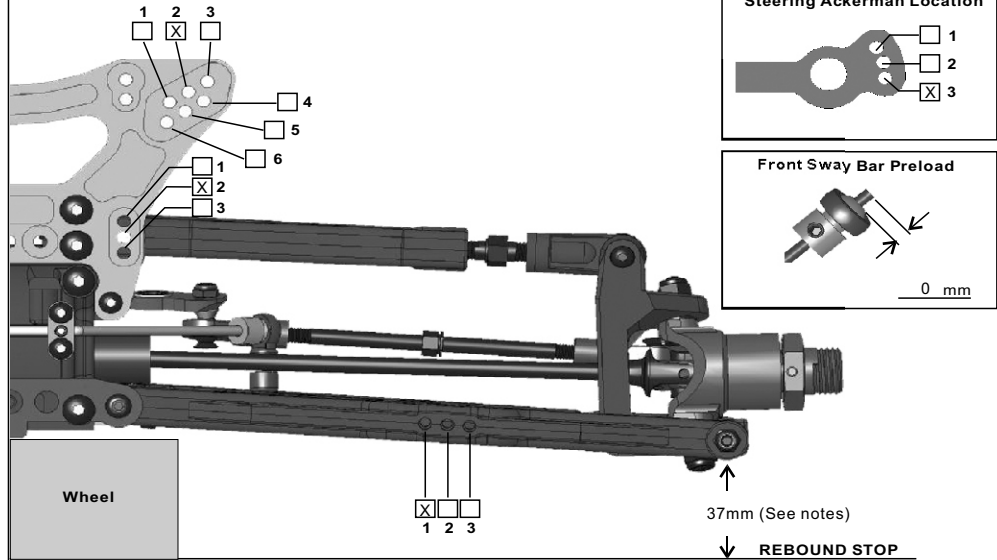
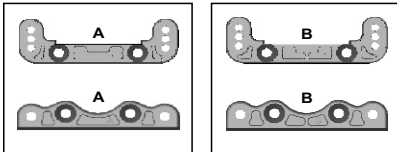

Notes: Use an unmounted CRT wheel under chassis and measure from table to outer rear of arm.

Rear Suspension

Shock Spring: Blue

Shock Piston: Standard Drilled

Shock Oil wt: 45 Losi

Shock Length (Bottom of body to shock end) N/A

Rear Ride Height: Slightly above arms level

Sway Bar: 2.3mm 2.5mm 2.8mm None

Camber: Neg: 3.5 Degrees

Pos:

Rear Hub/Wheelbase: Forward Middle Back Reversed

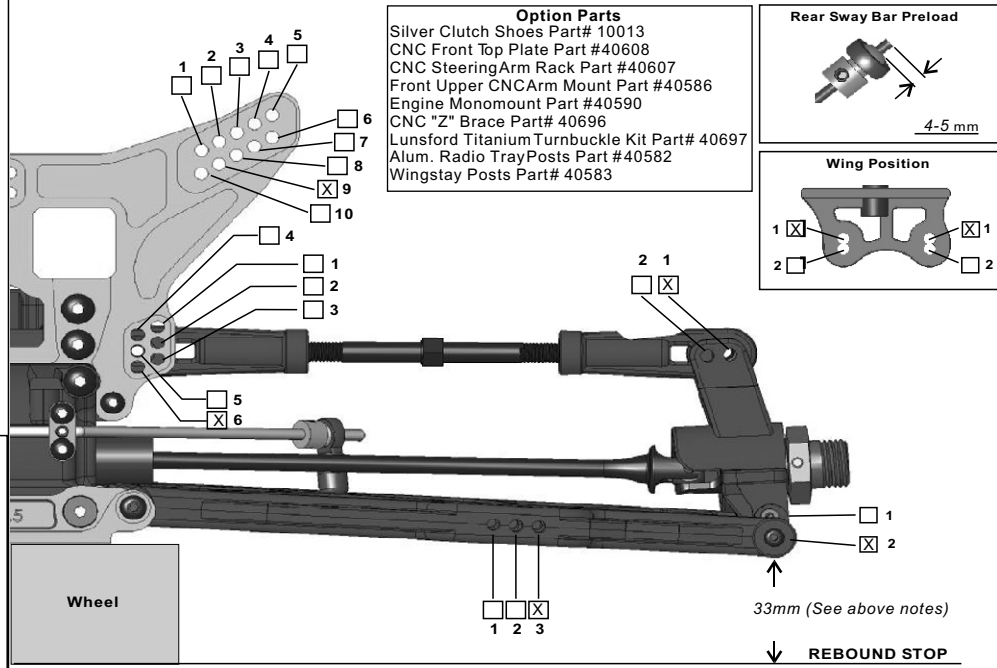
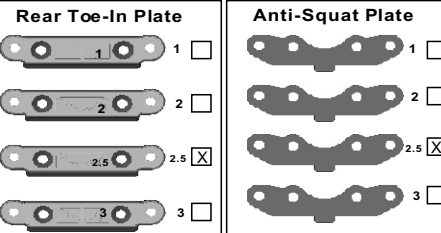

- Option Parts**
 Silver Clutch Shoes Part# 10013
 CNC Front Top Plate Part #40608
 CNC Steering Arm Rack Part #40607
 Front Upper CNC Arm Mount Part #40586
 Engine Monomount Part #40590
 CNC "Z" Brace Part# 40696
 Lunsford Titanium Turnbuckle Kit Part# 40697
 Alum. Radio Tray Posts Part #40582
 Wingstay Posts Part# 40583

Differential

Front Type: STD Torsen Oil 20K

Center Type: STD Torsen Oil 30K

Rear Type: STD Torsen Oil 1K

Tires

Front Type: PL Crime Bowtie MT Compound STD Foam: White

Rear Type: PL Crime Bowtie MT Compound STD Foam: White

Note: Tire mounted on inside of inner bead and rim trimmed

Engine

Type: OS VSpec .21

Head Clearance STD Port: STD

Pipe: Jammin JP-1

Fuel: WERKS 30%

Plug P3 Turbo Normal

CLUTCH

Shoe Brand: Jammin Compound: Alum: Silver Blue Red 3Shoes

Spring Brand: Jammin Tension: Gold Heavy 1.1mm 4 Shoes

Gearing: 13T 14T TO 62T Other T

Note: Prep clutch as per Tips on web site

Clutch Shoes:

2 Shoes

3 Shoes

4 Shoes