

# Jammin X1-CRT Set-Up Sheet

Driver: Chad Bradley

Track: The Silver State Warm-up Air Temp: 75F

Track Size	Traction	Surface
<input checked="" type="checkbox"/> open	<input type="checkbox"/> High	<input type="checkbox"/> Smooth
<input type="checkbox"/> Medium	<input checked="" type="checkbox"/> Medium	<input type="checkbox"/> Medium
<input type="checkbox"/> Tight	<input type="checkbox"/> Low	<input checked="" type="checkbox"/> Bumpy

## Front Suspension

Shock Spring: Blue

Shock Piston:  Standard  Drilled

Shock Oil wt: 55 Losi mixed

Shock Length  
(Bottom of body to shock end) N/A

Toe-IN:

Toe-Out:  3 Degree

Front Ride Height: Arms level

Sway Bar:  2mm  2.3mm  2.5mm

Camber:  Neg: 2 Degrees  
 Pos:

Caster Block:  A/A  B/B

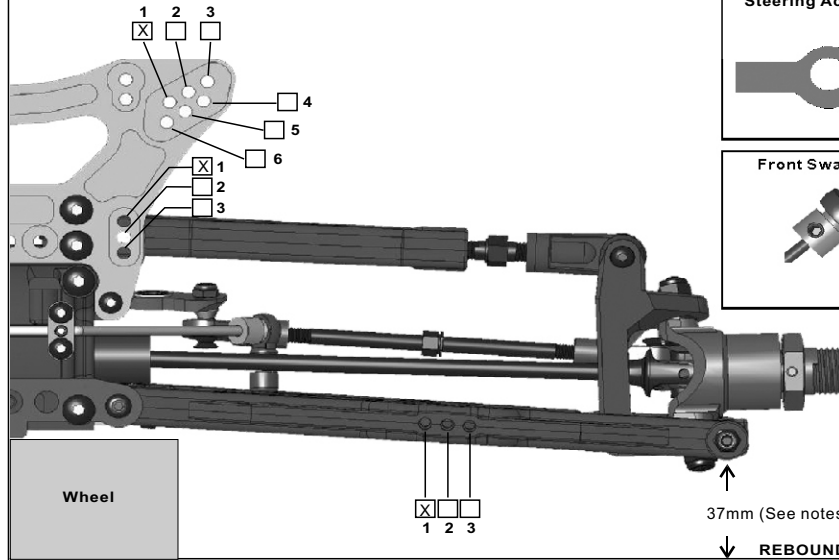
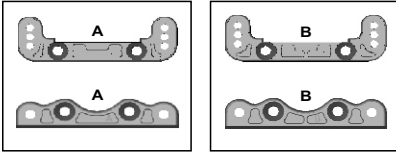

### Steering Ackerman Location



### Front Sway Bar Preload

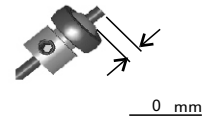

Notes: Use an unmounted CRT wheel under chassis and measure from table to outer rear of arm.

## Rear Suspension

Shock Spring: Blue

Shock Piston:  Standard  Drilled

Shock Oil wt: 45 Losi

Shock Length  
(Bottom of body to shock end) N/A

Rear Ride Height: Slightly above arms level

Sway Bar:  2.3mm  2.5mm  2.8mm  
 None

Camber:  Neg: 3 Degrees  
 Pos:

Rear Hub/Wheelbase:  Forward  Middle  
 Back

### Rear Toe-In Plate

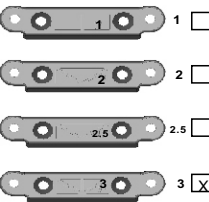

### Anti-Squat Plate

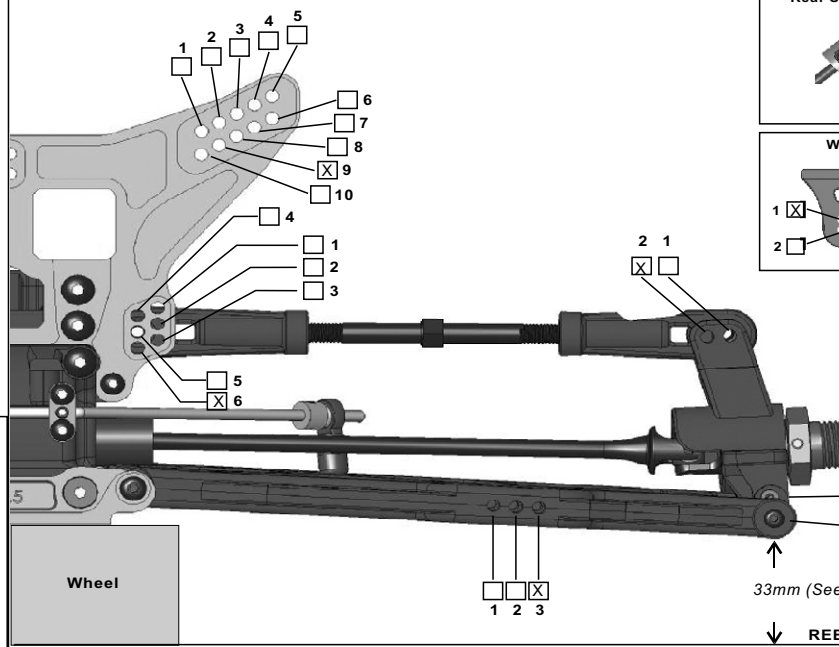
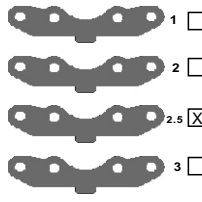

### Rear Sway Bar Preload

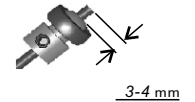

### Wing Position

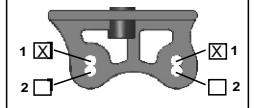

REBOUND STOP

## Differential

Front Type:  STD  Torsen Oil 7K

Center Type:  STD  Torsen Oil 20K

Rear Type:  STD  Torsen Oil 3K

## Tires

Front Type: PL Crime Fighter MT Compound STD Foam: STD

Rear Type: PL Crime Fighter MT Compound STD Foam: STD

Note: Tire mounted on inside of inner bead and rim trimmed

## Engine

Type: OS VSpec .21

Head Clearance STD Port: STD

Pipe: Jammin JP-1

Fuel: Byron RACE 30%

Plug A3  Turbo  Normal

## CLUTCH

Shoe Brand: Jammin Compound:  ALUM:  Blue  Red

Spring Brand: Jammin Tension: Gold Heavy 1.1mm

Gearing:  13T  14T TO  62T Other T

Note: Prep clutch as per Tips on web site

### Clutch Shoes:

2 Shoes

3 Shoes

4 Shoes