

# Jammin X1-CRT Set-Up Sheet

Track Size	Traction	Surface
<input checked="" type="checkbox"/> Open	<input checked="" type="checkbox"/> High	<input checked="" type="checkbox"/> Smooth
<input checked="" type="checkbox"/> Medium	<input checked="" type="checkbox"/> Medium	<input checked="" type="checkbox"/> Medium
<input checked="" type="checkbox"/> Tight	<input checked="" type="checkbox"/> Low	<input checked="" type="checkbox"/> Bumpy

Driver: Dean Sexton

Track: Any Track Date: 2005 Air Temp: 65 - 85F

## Front Suspension

Shock Spring: Blue

Shock Piston:  Standard  Drilled

Shock Oil wt: 50 Losi

Shock Length  
(Bottom of body to shock end) 25-26mm

Toe-IN:

Toe-Out:  1 Degree

Front Ride Height: Arms slightly below level

Sway Bar:  2mm  2.3mm  2.5mm

Camber:  Neg: 2 Degrees

Pos:

Caster Block:  A/A  B/B

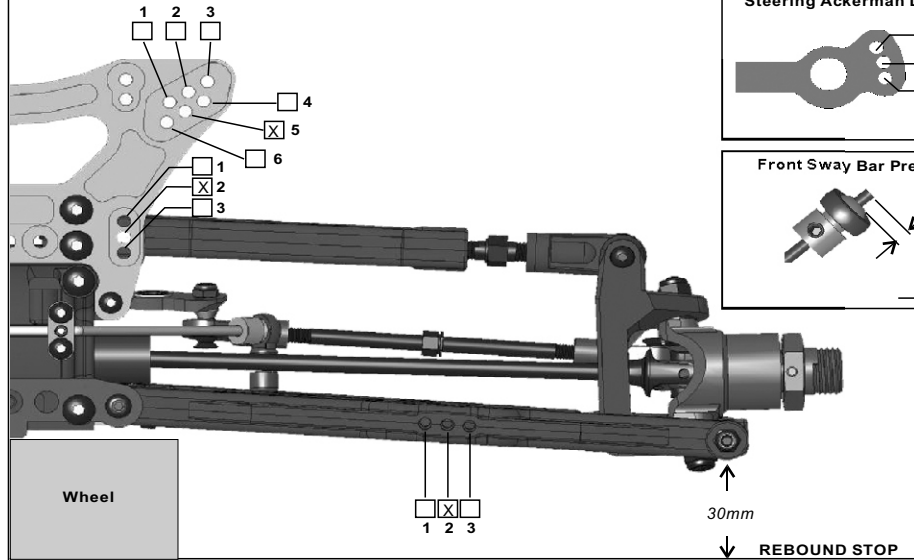
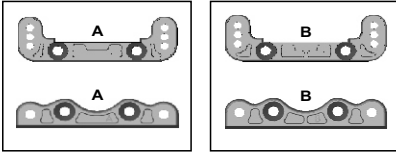

Steering Ackerman Location



Front Sway Bar Preload

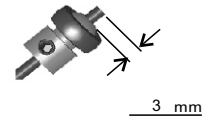

Notes: \_\_\_\_\_

## Rear Suspension

Shock Spring: Blue

Shock Piston:  Standard  Drilled #

Shock Oil wt: 50 Losi

Shock Length  
(Bottom of body to shock end) 39mm

Rear Ride Height: Arms level

Sway Bar:  2.3mm  2.5mm  2.8mm  
 None

Camber:  Neg: 3 Degrees

Pos:

Rear Hub/Wheelbase:  Forward  Middle  
 Reversed  Back

### Rear Toe-In Plate

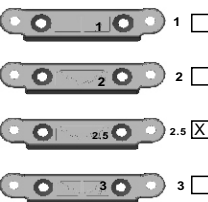

### Anti-Squat Plate

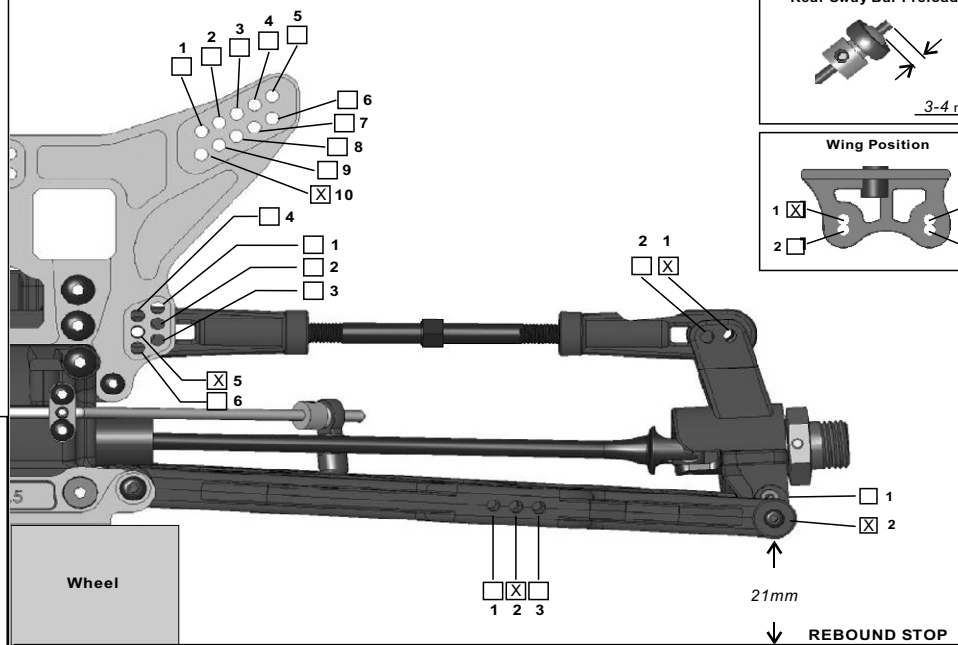
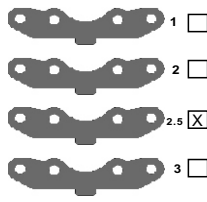

Rear Sway Bar Preload

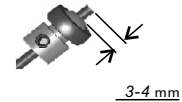

Wing Position

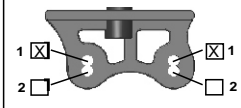

## Differential

Front Type:  STD  Torsen Oil 10K

Center Type:  STD  Torsen Oil 50K

Rear Type:  STD  Torsen Oil 5K

## Tires

Front Type: PL Crime Fighter MT Compound STD Foam: STD

Rear Type: PL Crime Fighter MT Compound STD Foam: STD

Note: Tire mounted on inside of inner bead and rim trimmed No tape

## Engine

Type: RB Corono Modified

Head Clearance STD Port: STD

Pipe: Jammin JP-1

Fuel: Byron RACE 30%

Plug  Turbo  Normal

## CLUTCH

Shoe Brand: Jammin Compound:  ALUM  Blue  Red

Spring Brand: Jammin Tension: Gold 1.1mm

Gearing:  13T  14T TO  62T Other T

Note: \_\_\_\_\_

### Clutch Shoes:

2 Shoes

3 Shoes

4 Shoes