

Jammin X1-CRT Set-Up Sheet

Track Size	Traction	Surface
<input checked="" type="checkbox"/> open	<input type="checkbox"/> High	<input checked="" type="checkbox"/> Smooth
<input type="checkbox"/> Medium	<input checked="" type="checkbox"/> Medium	<input type="checkbox"/> Medium
<input type="checkbox"/> Tight	<input type="checkbox"/> Low	<input type="checkbox"/> Bumpy

Driver: Matt Gosch

Track: Sun Valley Speedway RC Pro Finals Date 11-12-05 Air Temp: 65F

Front Suspension

Shock Spring: Blue
 Shock Piston: Standard Drilled#
 Shock Oil wt: 70 Asoc
 Shock Length
 (Bottom of body to shock end) 25-26mm
 Toe-IN:
 Toe-Out: 1Degree
 Front Ride Height: Arms slightly below level
 Sway Bar: 2mm 2.3mm 2.5mm
 Camber: Neg: 2 Degrees
 Pos:
 Caster Block: A/A B/B

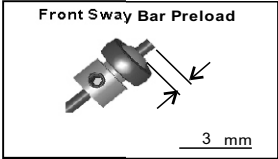
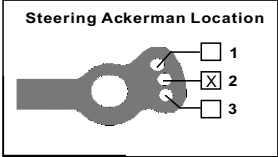
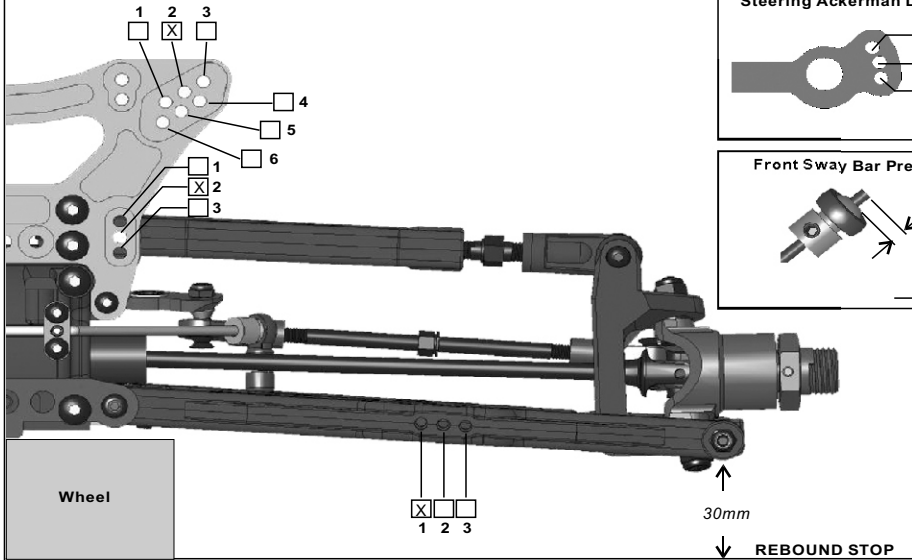
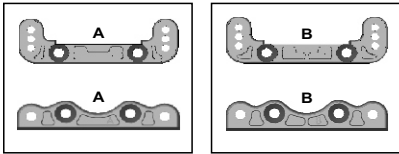

Notes: _____

Rear Suspension

Shock Spring: Blue
 Shock Piston: Standard Drilled #
 Shock Oil wt: 60 Asoc
 Shock Length
 (Bottom of body to shock end) 39mm
 Rear Ride Height: Arms level
 Sway Bar: 2.3mm 2.5mm 2.8mm
 None
 Camber: Neg: 3 Degrees
 Pos:
 Rear Hub/Wheelbase: Forward Middle
 Reversed Back

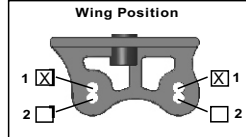
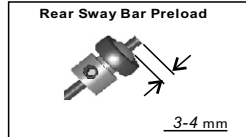
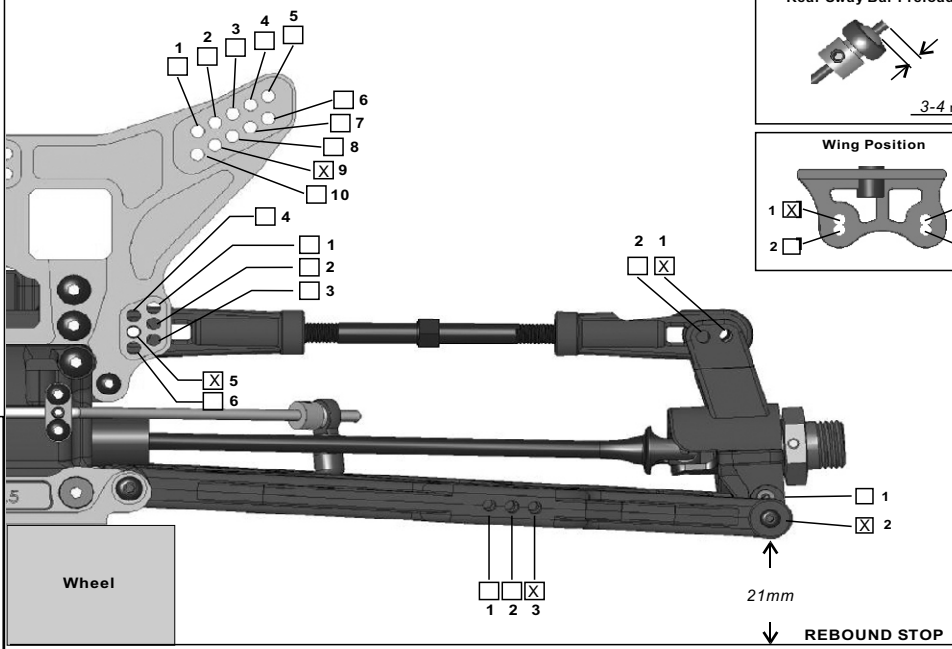
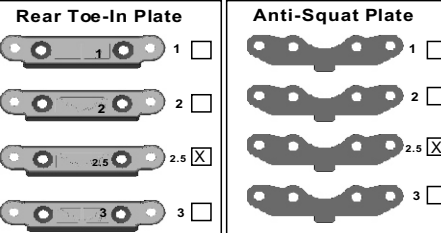

Differential

Front Type: STD Torsen Oil 5K
 Center Type: STD Torsen Oil 30K
 Rear Type: STD Torsen Oil 3K

Tires

Front Type: PL Crime Fighter MT Compound STD Foam: STD
 Rear Type: PL Crime Fighter MT Compound STD Foam: STD
 Note: Tire mounted on inside of inner bead and rim trimmed No tape

Engine

Type: Werks Collari .27
 Head Clearance STD Port: STD
 Pipe: RB 086
 Fuel: Byron RACE 30%
 Plug MC-9 Turbo Normal

CLUTCH

Shoe Brand: Kyosho Compound: Black Carbon ALUM: Blue Red
 Spring Brand: Jammin Tension: 1.0mm
 Gearing: 13T 14T TO 62T Other T
 Note: Shoes lightened on edge with Kyosho flywheel

Clutch Shoes:
 2 Shoes
 3 Shoes
 4 Shoes