

Jammin X1-CRT Set-Up Sheet

Track Size	Traction	Surface
<input type="checkbox"/> open	<input checked="" type="checkbox"/> High	<input checked="" type="checkbox"/> Smooth
<input type="checkbox"/> Medium	<input type="checkbox"/> Medium	<input type="checkbox"/> Medium
<input checked="" type="checkbox"/> Tight	<input type="checkbox"/> Low	<input type="checkbox"/> Bumpy

Driver: Matt Gosch

Track: CRCRC Indoor Nitro Champs, OH. Date 1-22-06 Air Temp: 60F

Front Suspension

Shock Spring: Mugen Grey

Shock Piston: Standard Drilled#56

Shock Oil wt: 40 Asoc

Shock Length
(Bottom of body to shock end) 29mm

Toe-IN: _____

Toe-Out: 1Degree

Front Ride Height: Arms slightly below level

Sway Bar: 2mm 2.3mm 2.5mm

Camber: Neg: 1 Degrees
 Pos: _____

Caster Block: A/A B/B

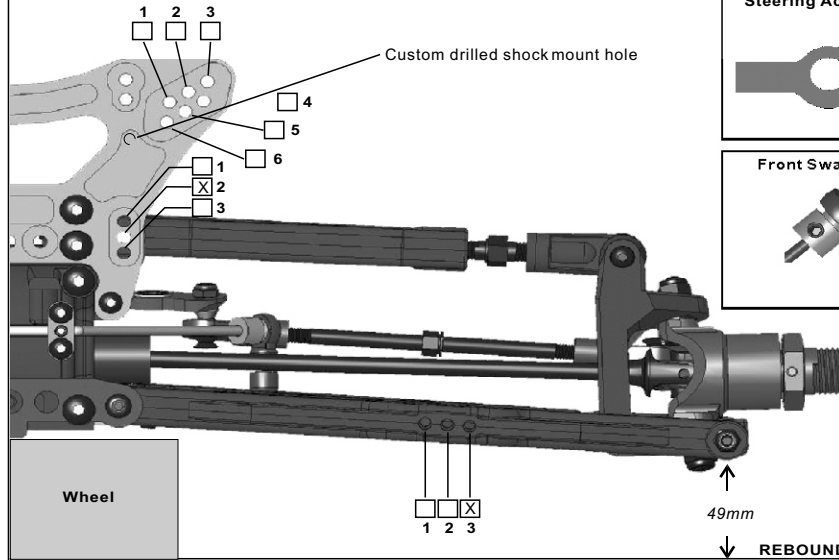
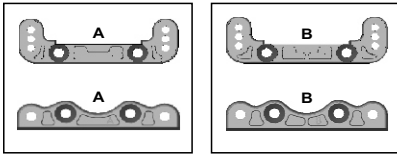

Steering Ackerman Location



Front Sway Bar Preload

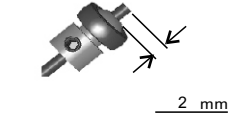

Notes: Piston holes plugged with steel wire and redrilled with #56 through plastic. Front & Rear.

Rear Suspension

Shock Spring: Blue

Shock Piston: Standard Drilled #56

Shock Oil wt: 40 Asoc

Shock Length
(Bottom of body to shock end) 35.5mm

Rear Ride Height: Arms level

Sway Bar: 2.3mm 2.5mm 2.8mm
 3.0 None

Camber: Neg: 1.5 Degrees
 Pos: _____

Rear Hub/Wheelbase: Forward Middle
 Reversed Back

Rear Toe-In Plate

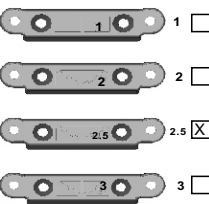

Anti-Squat Plate

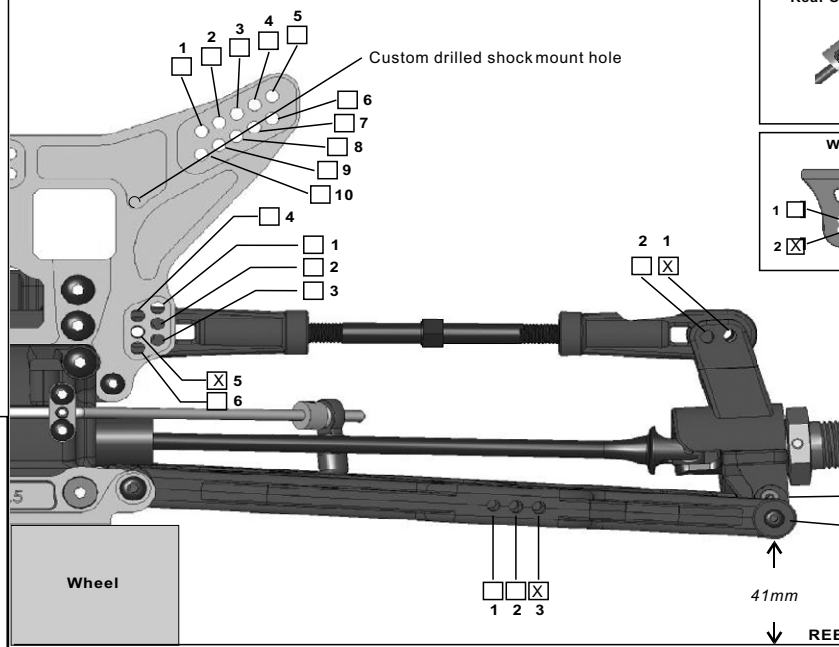
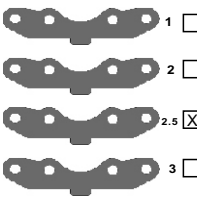

Rear Sway Bar Preload

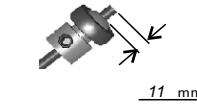

Wing Position



Differential

Front Type: STD Torsen Oil 5K

Center Type: STD Torsen Oil 20K

Rear Type: STD Torsen Oil 3K

Tires

Front Type: PL Crime Fighter MT Compound STD Foam: STD

Rear Type: PL Crime Fighter MT Compound STD Foam: STD

Note: Tire lugs cut to half height

Engine

Type: Werks Collari .28

Head Clearance STD Port: STD

Pipe: RB 9886

Fuel: Byron RACE 30%

Plug MC-9 Turbo Normal

CLUTCH

Shoe Brand: Jammin Compound: ALUM Blue Red

Spring Brand: Jammin Tension: Gold 1.1mm

Gearing: 13T 14T TO 62T Other T

Note: _____

Clutch Shoes:

2 Shoes

3 Shoes

4 Shoes