

Driver: Chad Bradley

Date: 2/18/06

Track: The Dirt Nitro Challenge

AirTemp: 50-60

F C

TRACK: SIZE

TRACTION:

SURFACE:

- OPEN
 MEDIUM
 TIGHT

- HIGH
 MEDIUM
 LOW

- DUST
 MEDIUM
 BUMPY

Front Suspension

Shock Spring: Grey

Shock Piston: Standard Drilled

Shock Oil wt: 45 wt. Losi

Shock Length (Center to Center) _____ mm

Toe-IN: _____

Toe-Out: 2 degrees

Front Ride Height: Arms level

Sway Bar: 2mm 2.3mm 2.5mm
 _____ None

Camber: Neg: 2 degrees

Pos: _____

Caster Block: A/A B/B

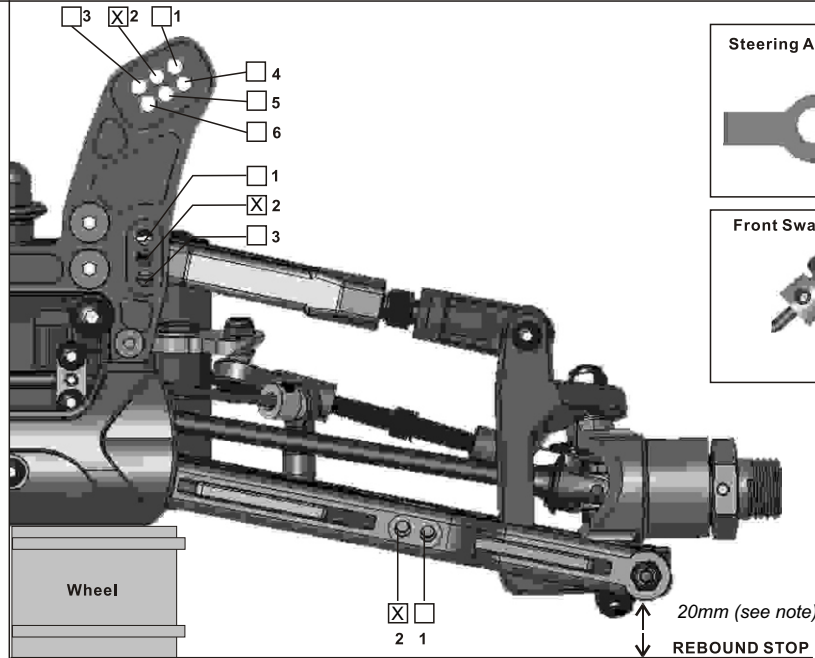
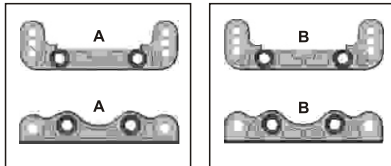

Steering Ackerman Location



Front Sway Bar Preload

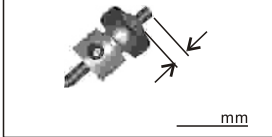

Notes: To get this droop level, the hub carrier at the arm must be cleared with Dremel

Rear Suspension

Shock Spring: Grey

Shock Piston: Standard Drilled

Shock Oil wt: 35wt Losi

Shock Length (Center to Center) _____ mm

Rear Ride Height: Arms level

Sway Bar: 2.3mm 2.5mm 2.8mm
 _____ None

Camber: Neg: 3.5 degrees

Pos: _____

Rear Hub/Wheelbase: Forward Middle
 Back

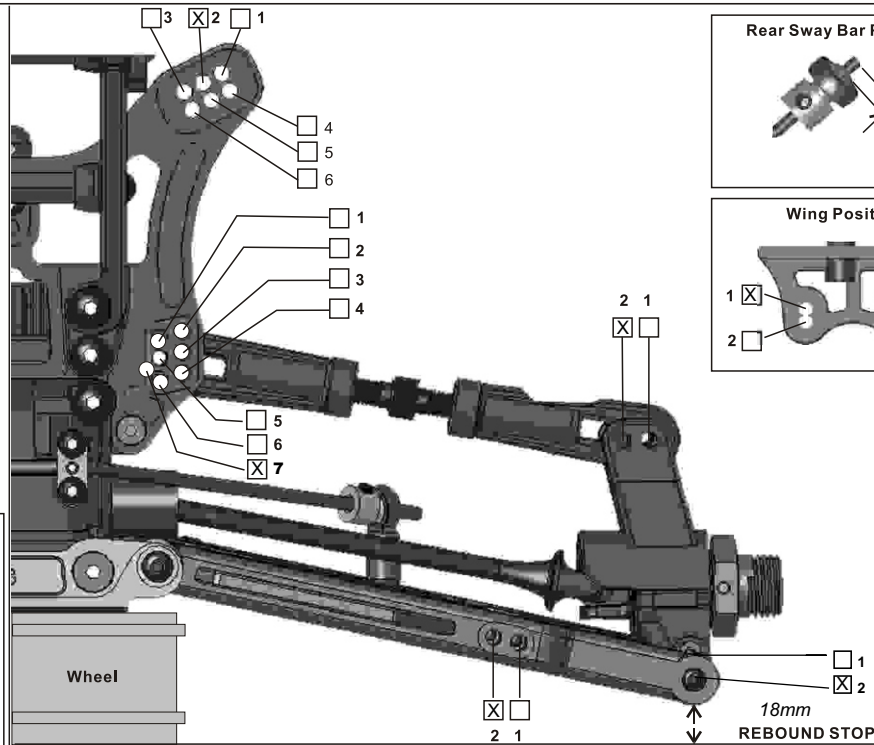
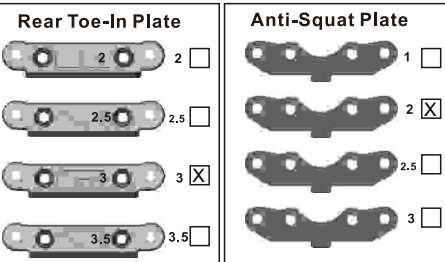

Rear Sway Bar Preload

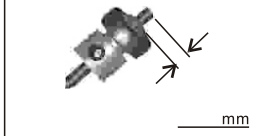

Wing Position

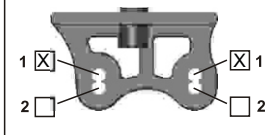

Differential

Front Type: STD Torsen Oil: 5 K

Center Type: STD Torsen Oil: 7 K

Rear Type: STD Torsen Oil: 2 K

Tires

Front Type: Proline Compound M3

Insert Foam: Proline Grey Molded

Rear Type: Proline Compound M3

Insert Foam: Proline Grey Molded

Note: _____

Engine

Type: O.S. V Spec Port: _____

Plug: P3 Normal Turbo

Head Clearance: Std.

Pipe: 2050

Fuel Brand: Werks / 30 %

CLUTCH

Shoe Brand: Jammin Compound Blue Alum. ALUM: Blue Purple

Spring Brand: Jammin Tension Black Spring 1.0 mm

Gearing: 13T 14T To 46T 48T

Note: _____

Clutch Shoes:

- 2 Shoe
 3 Shoe
 4 Shoe
