

Driver: Gary Guest

Revelation Raceway
Best of the West

Date: 12/3/06

Track: _____

AirTemp: 50

F C

TRACK: SIZE

TRACTION:

SURFACE:

- OPEN
 MEDIUM
 TIGHT

- HIGH
 MEDIUM
 LOW

- DUST
 MEDIUM
 BUMPY

Front Suspension

Shock Spring: Mugen Grey

Shock Piston: Standard Drilled

Shock Oil wt: 40 wt. Losi

Shock Length
(Center to Center) 105 mm

Toe-IN:

Toe-Out: 2 degrees

Front Ride Height: Arms slightly above level

Sway Bar: 2mm 2.3mm 2.5mm
 None

Camber: Neg: 2 degrees

Pos: _____

Caster Block: A/A B/B

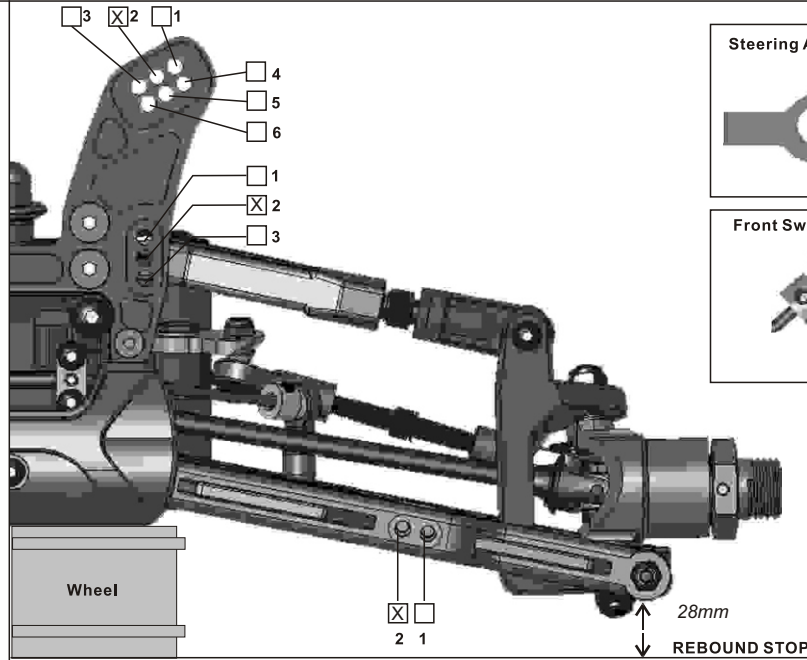
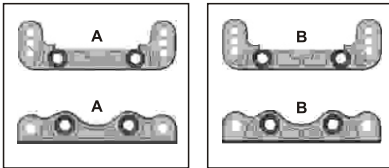

Steering Ackerman Location



Front Sway Bar Preload

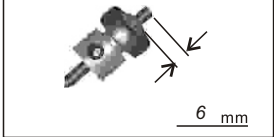

Notes: There was more traction during the day, so I used Mugen
Blue springs for more steering.

Rear Suspension

Shock Spring: Mugen Grey

Shock Piston: Standard Drilled

Shock Oil wt: 35wt Losi

Shock Length
(Center to Center) 122 mm

Rear Ride Height: Arms level

Sway Bar: 2.3mm 2.5mm 2.8mm
 None

Camber: Neg: 3 degrees

Pos: _____

Rear Hub/Wheelbase: Forward Middle
 Back

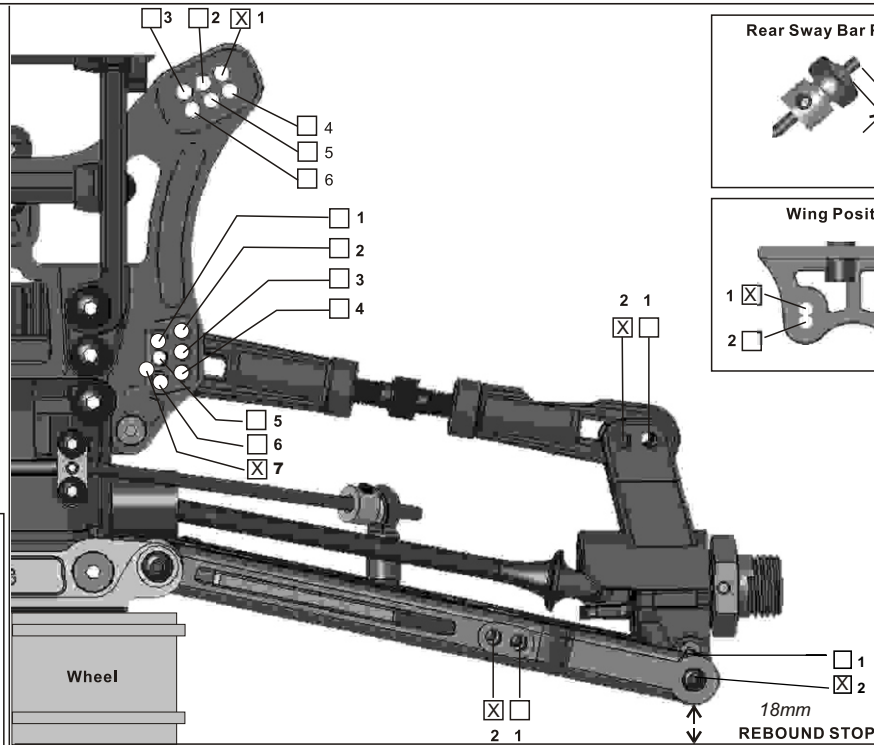
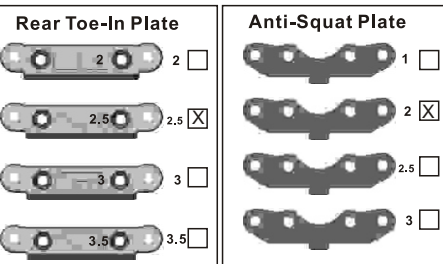

Rear Sway Bar Preload

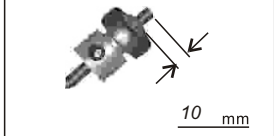

Wing Position

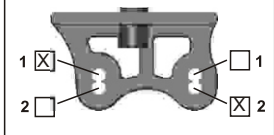

Differential

Front Type: STD Torsen Oil: 5 K

Center Type: STD Torsen Oil: 7 K

Rear Type: STD Torsen Oil: 2 K

Tires

Front Type: Proline Bowtie Compound M3

Insert Foam: Proline Standard

Rear Type: Proline Bowtie Compound M3

Insert Foam: Proline Standard

Note: _____

Engine

Type: Picco EVO 2 Port: _____

Plug: O'Donnell 77 Normal Turbo

Head Clearance: 0.023"

Pipe: Jammin JP-3

Fuel Brand: SideWinder WC Blend / 30 %

CLUTCH

Shoe Brand: MIP Light Compound Carbon ALUM: Blue Purple

Spring Brand: MIP Tension Standard mm

Gearing: 13T 14T To 46T 48T

Note: _____

Clutch Shoes:

- 2 Shoe
 3 Shoe
 4 Shoe
