

TRACK: SIZE	TRACTION:	SURFACE:
<input type="checkbox"/> OPEN	<input type="checkbox"/> HIGH	<input type="checkbox"/> DUST
<input checked="" type="checkbox"/> MEDIUM	<input checked="" type="checkbox"/> MEDIUM	<input type="checkbox"/> MEDIUM
<input type="checkbox"/> TIGHT	<input type="checkbox"/> LOW	<input checked="" type="checkbox"/> BUMPY

Driver: Taylor James

Date: 2/18/06

Track: The Dirt Nitro Challenge

AirTemp: 50-60 F C

Front Suspension

Shock Spring: Red

Shock Piston: Standard Drilled

Shock Oil wt: 45 wt. Assoc.

Shock Length (Center to Center) _____ mm

Toe-IN: _____

Toe-Out: 1 degrees

Front Ride Height: Arms level

Sway Bar: 2mm 2.3mm 2.5mm
 _____ None

Camber: Neg: 2 degrees

Pos: _____

Caster Block: A/A B/B

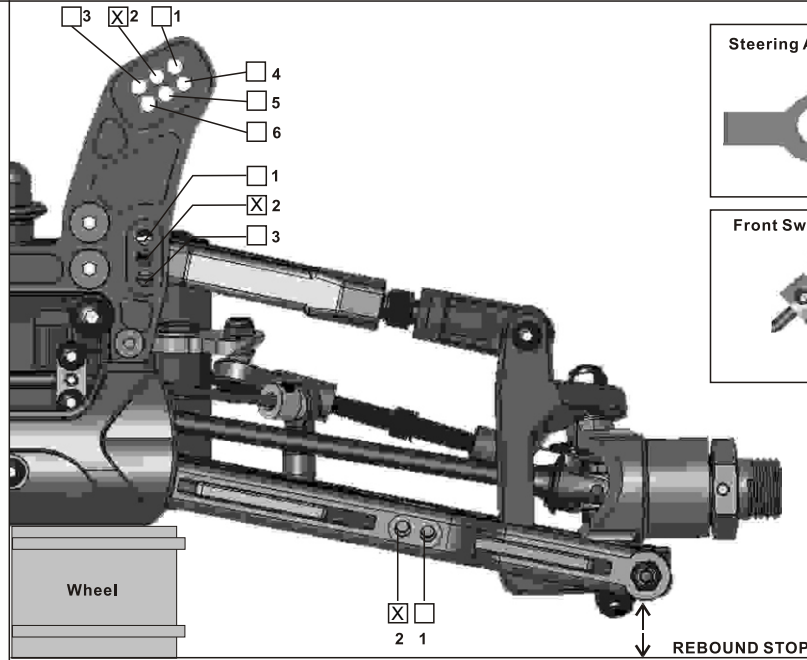
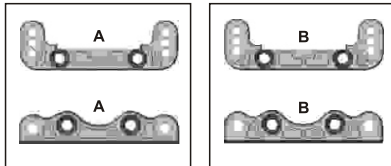

Steering Ackerman Location

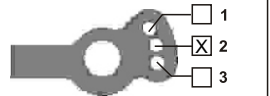

Front Sway Bar Preload

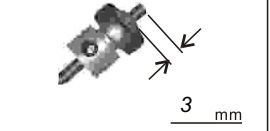

Notes: _____

Rear Suspension

Shock Spring: Grey

Shock Piston: Standard Drilled

Shock Oil wt: 35wt Losi

Shock Length (Center to Center) _____ mm

Rear Ride Height: Arms level

Sway Bar: 2.3mm 2.5mm 2.8mm
 _____ None

Camber: Neg: 3.5 degrees

Pos: _____

Rear Hub/Wheelbase: Forward Middle
 Back

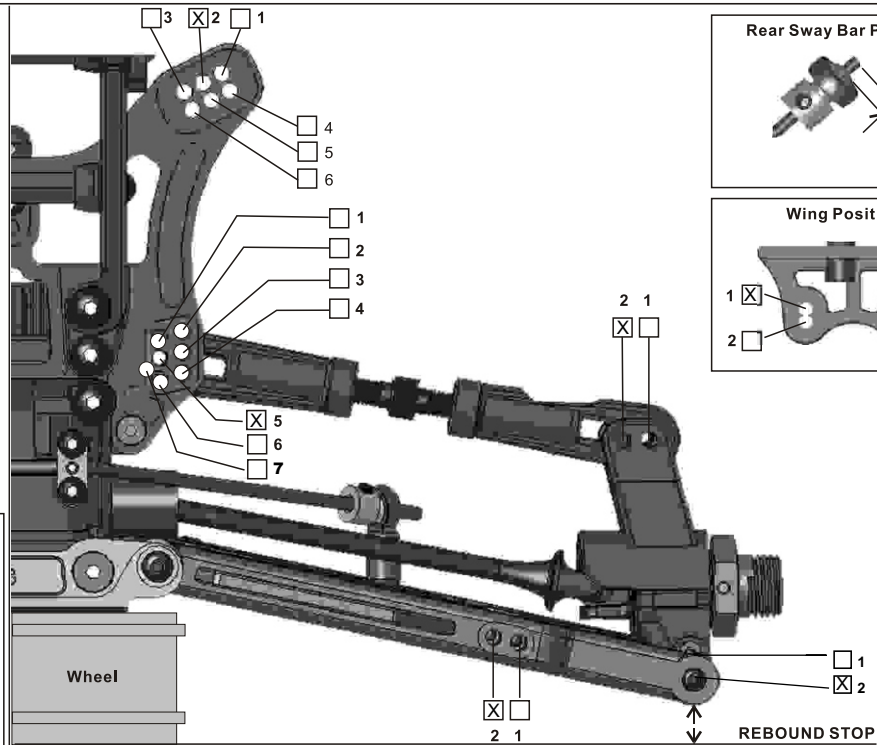
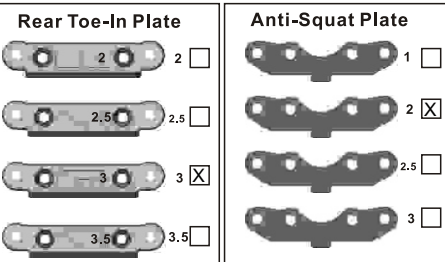

Rear Sway Bar Preload

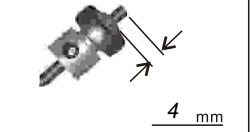

Wing Position

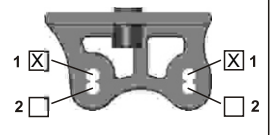

Differential

Front Type: STD Torsen Oil: 5 K

Center Type: STD Torsen Oil: 7 K

Rear Type: STD Torsen Oil: 3 K

Tires

Front Type: Proline Crime Fighter Compound M2

Insert Foam: Proline Grey

Rear Type: Proline Crime Fighter Compound M2

Insert Foam: Proline Grey

Note: _____

Engine

Type: O.S. V Spec Port: _____

Plug: O'Donnell Normal Turbo

Head Clearance: Std.

Pipe: OS 2050

Fuel Brand: O'Donnell / 30 %

CLUTCH

Shoe Brand: Jammin Compound Blue Alum. ALUM: Blue Purple

Spring Brand: Jammin Tension God Spring 1.1 mm

Gearing: 13T 14T To 46T 48T

Note: _____

Clutch Shoes:

2 Shoe

3 Shoe

4 Shoe
