

Driver: Adam Drake

Track: The Dirt, Proline, The Dirt County (Ohio) Air Temp: 90'sF Surface Description: Loam & Hard Pack Avg. Lap Time:

Front Suspension

Shock Spring: Blue

Shock Piston: 53/53

Shock Oil wt: 50 wt.

Shock Length (Center to Center): N/a

Toe-IN:

Toe-Out: 2 degrees

Front Ride Height: Just below rear

Sway Bar: 2.0mm

Camber: Neg: 2 degrees

Pos:

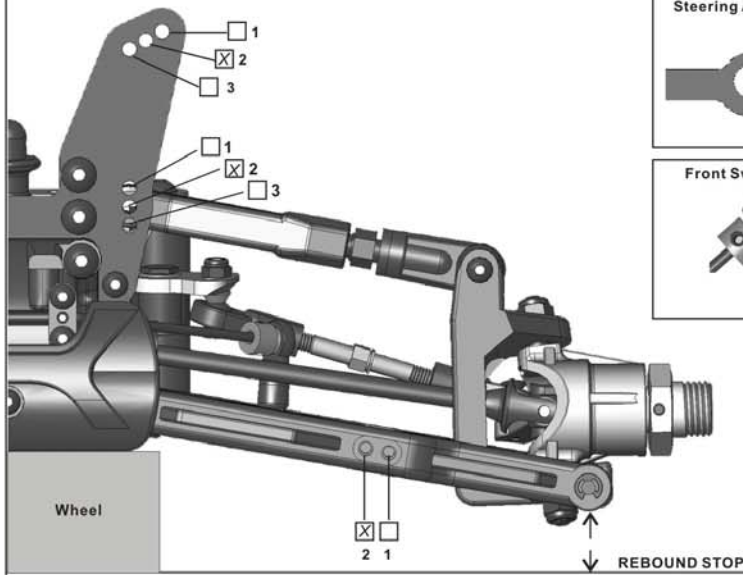
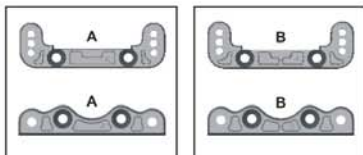
 Camber Block: A/A B/B

Steering Ackerman Location



Front Sway Bar Preload

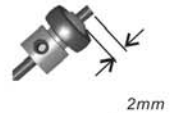

Notes: #3 upper arm location if track gets rough or slick

Rear Suspension

Shock Spring: Blue

Shock Piston: 53/53

Shock Oil wt: 40 wt.

Shock Length (Center to Center): N/a

Rear Ride Height: Arms level

Sway Bar: 2.6mm

Camber: Neg: 2.5 degrees

Pos:

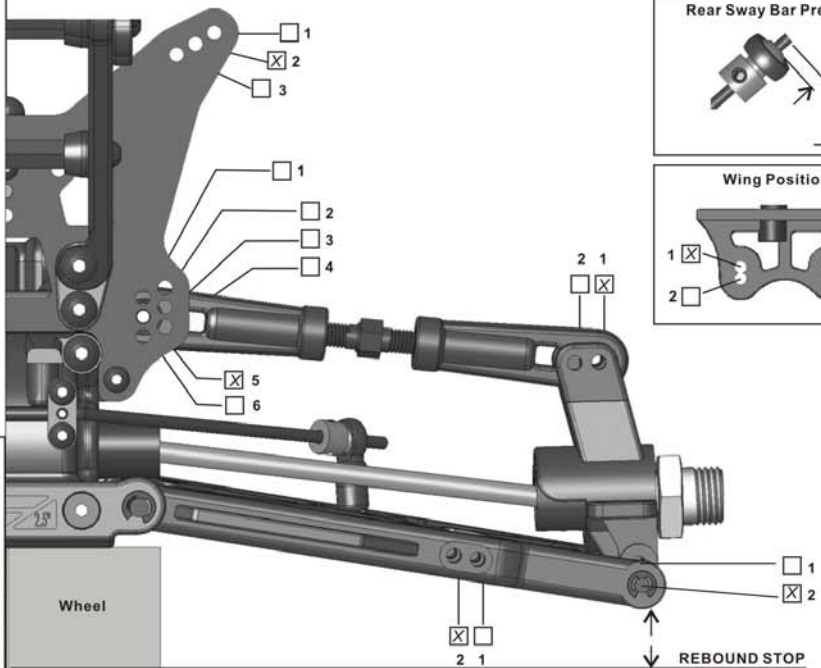
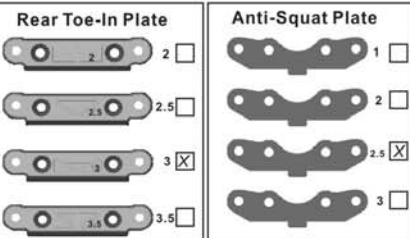
 Rear Hub/Wheelbase: Forward Middle Back

Rear Sway Bar Preload



Wing Position



Differentials

Front Type: Standard Oil: 5,000

Center Type: Standard Oil: 10,000

Rear Type: Standard Oil: 5,000

Tires

Front Type: P.L. CrimeFighter Compound: M2 Foam: Stock

Rear Type: P.L. CrimeFighter Compound: M2 Foam: Stock

Note:

Engine

Type: Sirio

Head Clearance: .023" Pipe: Sirio 2008

Fuel: Trinity % 30 Plug: #7

Needle (Top): (Bottom):

Note:

Clutch

Shoe Brand: Kyosho Compound: Black

Spring Brand: Kyosho Tension: 1.0mm

 Gearing: 13T 14T To 46T 48T

Note: 3/32" hole in each shoe trailing edge