



Jammin X1-CR Set-Up Sheet

Date: 11/2005

Driver: Adam Drake

Track: KZ Speedway - R/C Pro Finals

Air Temp: 65'sF

Surface Description: Clay Wet or Dry

Avg. Lap Time:

Front Suspension

Shock Spring: Jammin Red

Shock Piston: Stock Big Bore

Shock Oil wt: 45 wt. Losi

Shock Length (Center to Center): N/A

Toe-IN:

Toe-Out: 1 degree

Front Ride Height: Front arms level

Sway Bar: 2.6mm

Camber: Neg: 2 degrees

Pos:

Camber Block: A/A B/B

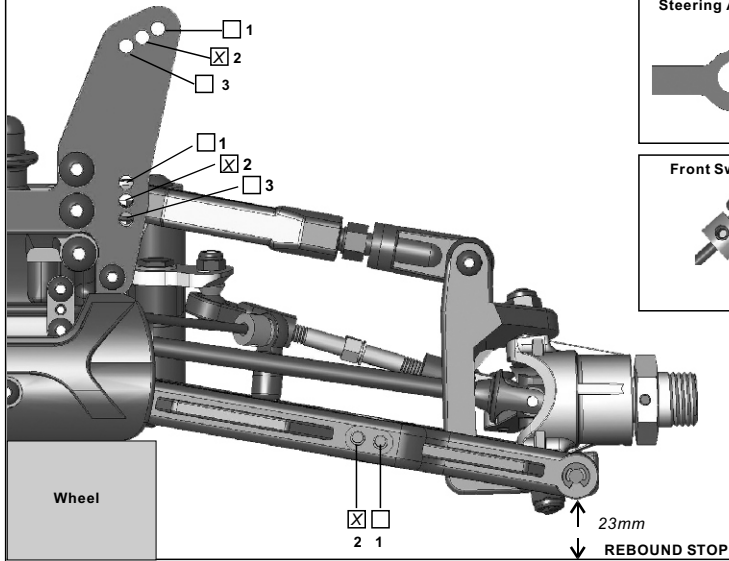
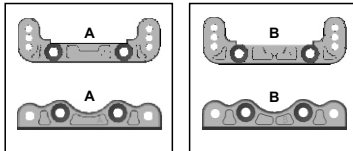

Steering Ackerman Location



Front Sway Bar Preload

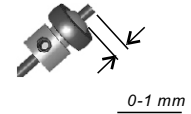

Notes:

Rear Suspension

Shock Spring: Jammin Red

Shock Piston: Stock Big Bore

Shock Oil wt: 32.5 wt. Losi

Shock Length (Center to Center): N/A

Rear Ride Height: Arms parallel with ground

Sway Bar: 2.5mm

Camber: Neg: 2 degrees

Pos:

Rear Hub/Wheelbase: Forward Middle Back

Rear Toe-In Plate

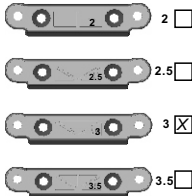

Anti-Squat Plate

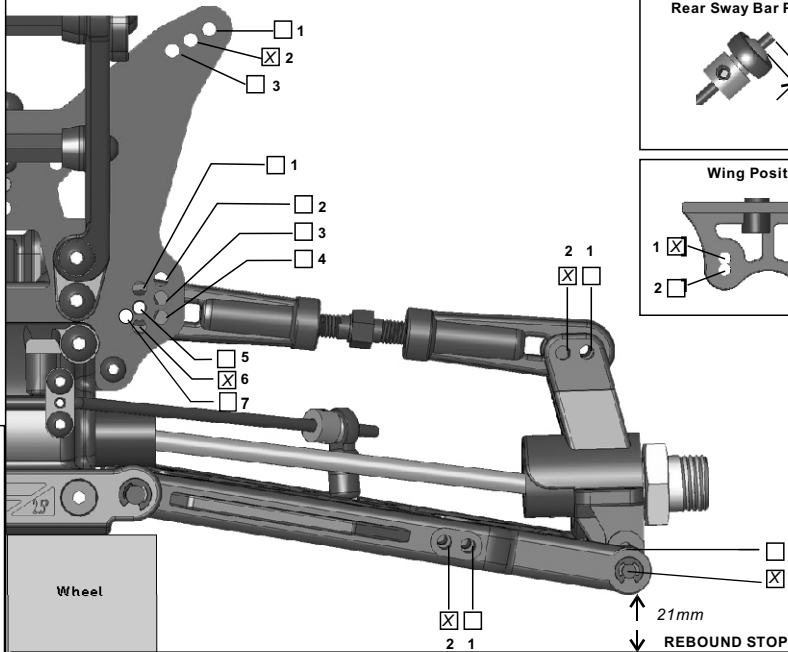
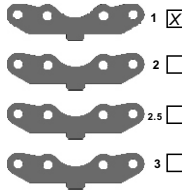

Rear Sway Bar Preload

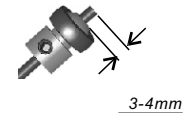

Wing Position

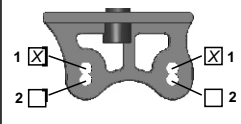

Differentials

Front Type: Standard Oil: 5,000

Center Type: Standard Oil: 7,000

Rear Type: Standard Oil: 2,000

Tires

Front Type: P.L. Inside Jobs Compound: M2 Foam: Stock

Rear Type: P.L. Inside Jobs Compound: M2 Foam: Stock

Note:

Engine

Type: Trinity Sirio

Head Clearance: Std. Pipe: Jammin JP-1

Fuel: Trinity Platinum %30 Plug: OD 99

Needle (Top): (Bottom):

Note:

Clutch

Shoe Brand: Jammin X1-CR Stock Compound: Blue Aluminum

Spring Brand: Jammin X1-CR Tension: X1-CR Stock 1.0mm Black

Gearing: 13T 14T To 46T 48T

Note: