

Driver: Chad Bradley

 Track: KZ Speedway - R/C Pro Finals

 Air Temp: 65'sF

 Surface Description: Clay Wet or Dry

Avg. Lap Time: _____

Front Suspension

 Shock Spring: Mugen Grey

 Shock Piston: Stock Big Bore

 Shock Oil wt: 47.5 wt. Losi (mixed)

 Shock Length: 30.5mm (Measured from bottom of shock end to bottom of body) (Center to Center):

Toe-IN: _____

 Toe-Out: 1 degree

 Front Ride Height: Front arms level

 Sway Bar: 2.5mm

 Camber: Neg: 2 degrees

Pos: _____

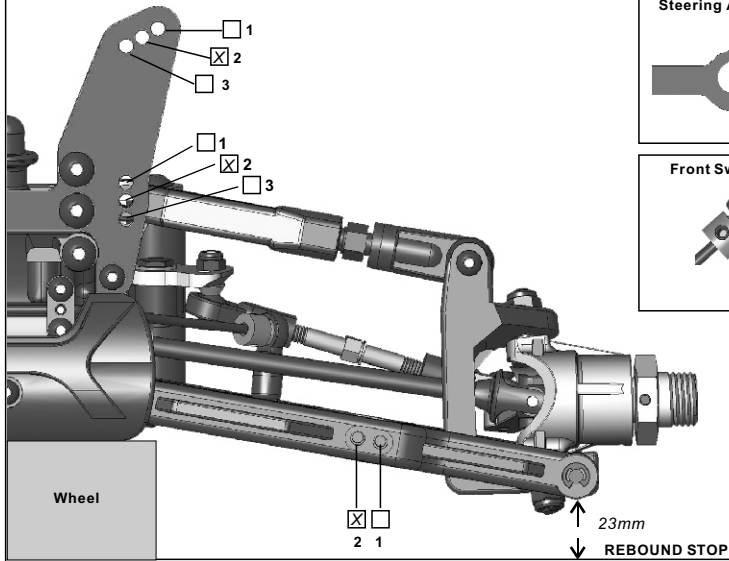
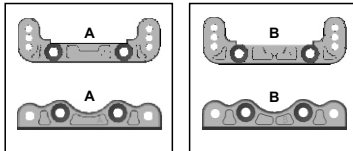
 Camber Block: A/A B/B

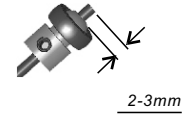
Steering Ackerman Location

Front Sway Bar Preload

Notes: _____

Rear Suspension

 Shock Spring: Mugen Grey

 Shock Piston: Stock Big Bore

 Shock Oil wt: 45 wt. Losi

 Shock Length: 34mm (Measured from bottom of shock end to bottom of body) (Center to Center):

 Rear Ride Height: Arms parallel with ground

 Sway Bar: 2.8mm

 Camber: Neg: 2.5 degrees

Pos: _____

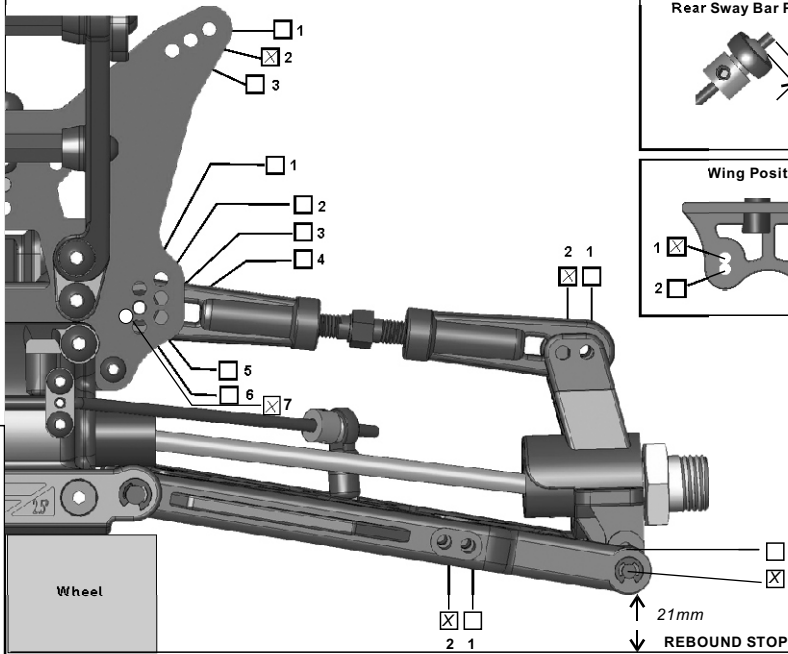
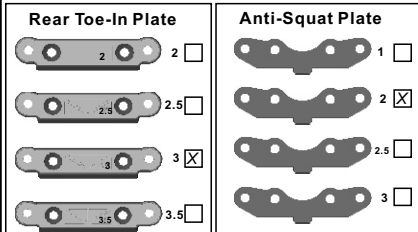
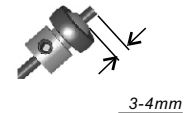
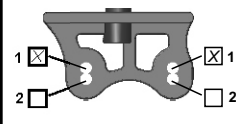
 Rear Hub/Wheelbase: Forward Middle Back

Rear Sway Bar Preload

Wing Position

Differentials

 Front Type: Standard Oil: 4,000

 Center Type: Standard Oil: 6,000

 Rear Type: Standard Oil: 2,000

Tires

 Front Type: P.L. CrimeFighter Compound: M2 Foam: Stock

 Rear Type: P.L. CrimeFighter Compound: M2 Foam: Stock

Note: _____

Engine

 Type: OS Vspec

 Head Clearance: Std. Pipe: OS 2060

 Fuel: Byron's % 30 Plug: A3

Needle (Top): _____ (Bottom): _____

Note: _____

Clutch

 Shoe Brand: Jammin X1-CR Stock Compound: Blue Aluminum

 Spring Brand: Jammin X1-CR Tension: X1-CR Stock 1.0mm Black

 Gearing: 13T 14T To 46T 48T

Note: _____