

Driver: Ryan McCreary

Track: Base Set-up

Air Temp: 60 F +

Surface Description: All

Avg. Lap Time:

Front Suspension

Shock Spring: Mugen Blue

Shock Piston: Standard

Shock Oil wt: 45 Losi

Shock Length (Center to Center): Short Shock End

Toe-IN:

Toe-Out: 1.5

Front Ride Height:

Sway Bar: 2.3mm

Camber: Neg: 1.5 - 2

Pos:

Camber Block: A/A B/B

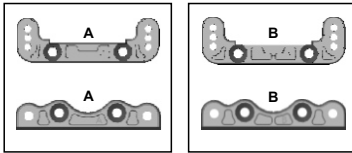

Optional Parts	Part #
Silver Clutch Shoes	#10013
CNC Front Top Plate	#40608
CNC Steering Arm Rack	#40607
Front Upper CNC Arm Mount	#40586
Engine Monomount	#40590
CNC "Z" Brace	#40696
Lunsford Ti Turnbuckle Kit	#40670
Alum. Radio Tray Posts	#40582
Wingstay Posts	#40583
CNC Billet Rear Hubs	#40609
CNC Center Diff. Mount	#40610

Steering Ackerman Location



Front Sway Bar Preload

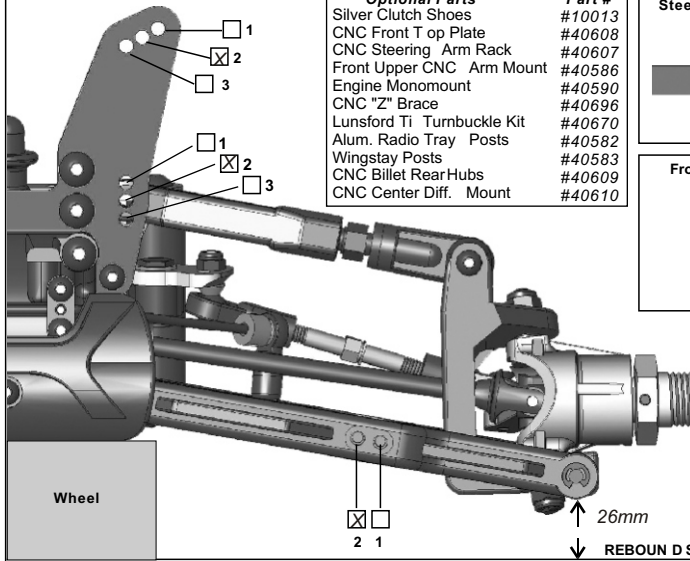
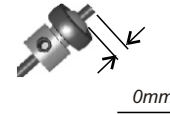

Notes:

Rear Suspension

Shock Spring: Mugen Blue

Shock Piston: Standard

Shock Oil wt: 37.5 Losi

Shock Length (Center to Center): Short Shock End

Rear Ride Height: Level

Sway Bar: 2.8mm

Camber: Neg: 3.5 - 4

Pos:

Rear Hub/Wheelbase: Forward Middle Back

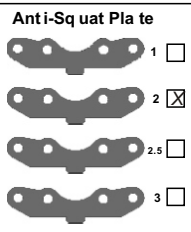
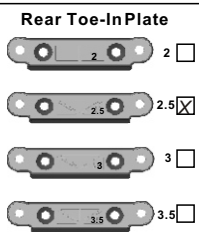

Rear Sway Bar Preload

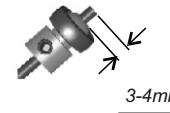

Wing Position

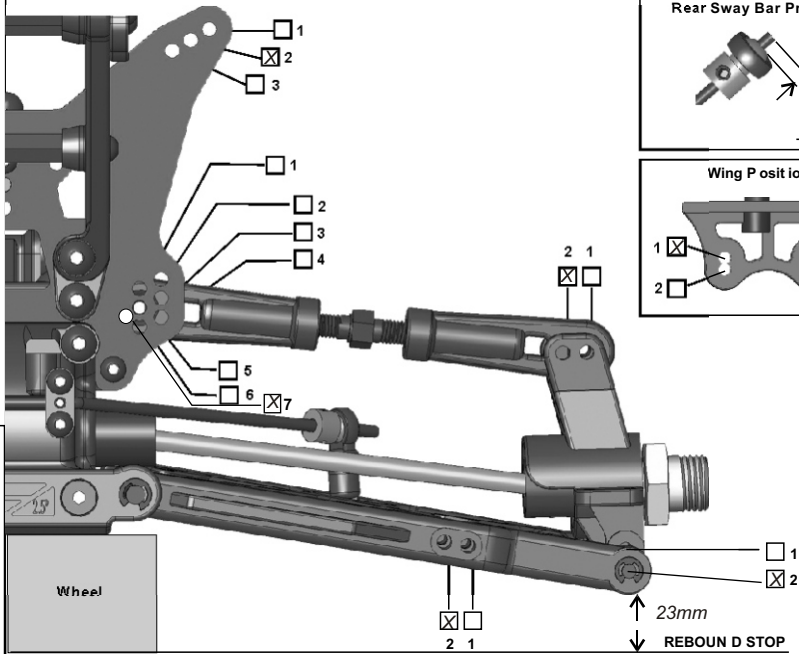
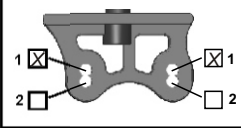

Differentials

Front Type: Std Oil: 5k

Center Type: Std Oil: 7k

Rear Type: Std Oil: 2k

Tires

Front Type: Proline Bowtie Compound: M3 Foam: Molded

Rear Type: Proline Bowtie Compound: M3 Foam: Molded

Note:

Engine

Type: Jammin 21

Head Clearance: .21 Pipe: Jammin JP-2

Fuel: Werks % 30 Plug:

Needle (Top): (Bottom):

Note:

Clutch

Shoe Brand: Jammin 3 shoe Compound: Silver

Spring Brand: Jammin Tension: Gold

Gearing: 13T 14T To 46T 48T

Note: