

Driver: Adam Drake

 Track: CRCRC Ohio Nitro Challenge

 Air Temp: 65'sF

 Surface Description: Indoor Clay

Avg. Lap Time: _____

Front Suspension

 Shock Spring: Jammin Red

 Shock Piston: Drilled #54

 Shock Oil wt: 37.5 wt. Losi

 Shock Length
(Center to Center): N/A

Toe-IN: _____

 Toe-Out: 1 degree

 Front Ride Height: Front arms level

 Sway Bar: 2.6mm

 Camber: Neg: 2 degrees

Pos: _____

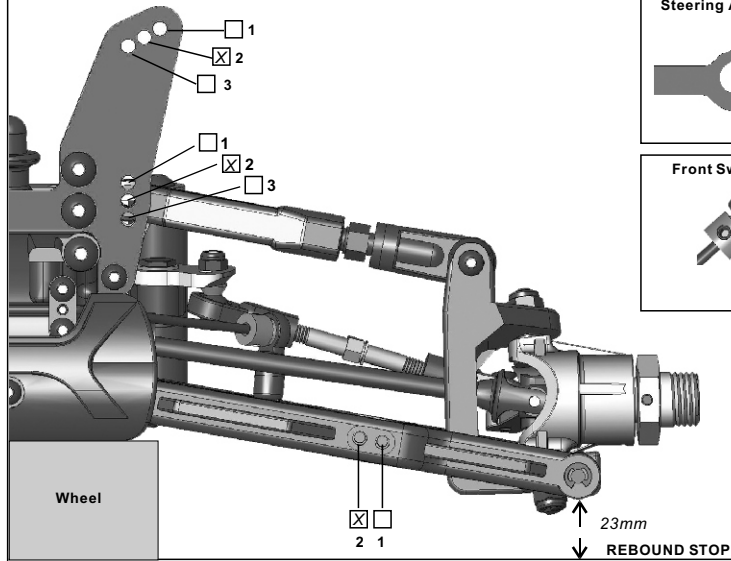
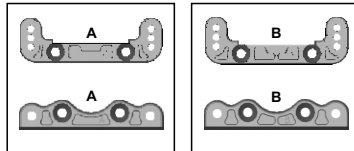
 Camber Block: A/A B/B

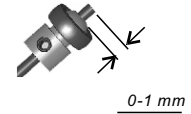
Steering Ackerman Location

Front Sway Bar Preload

Notes: _____

Rear Suspension

 Shock Spring: Jammin Red

 Shock Piston: Drilled #54

 Shock Oil wt: 25 wt. Losi

 Shock Length
(Center to Center): N/A

 Rear Ride Height: Arms parallel with ground

 Sway Bar: 2.5mm

 Camber: Neg: 2 degrees

Pos: _____

 Rear Hub/Wheelbase: Forward
 Middle
 Back

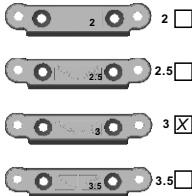
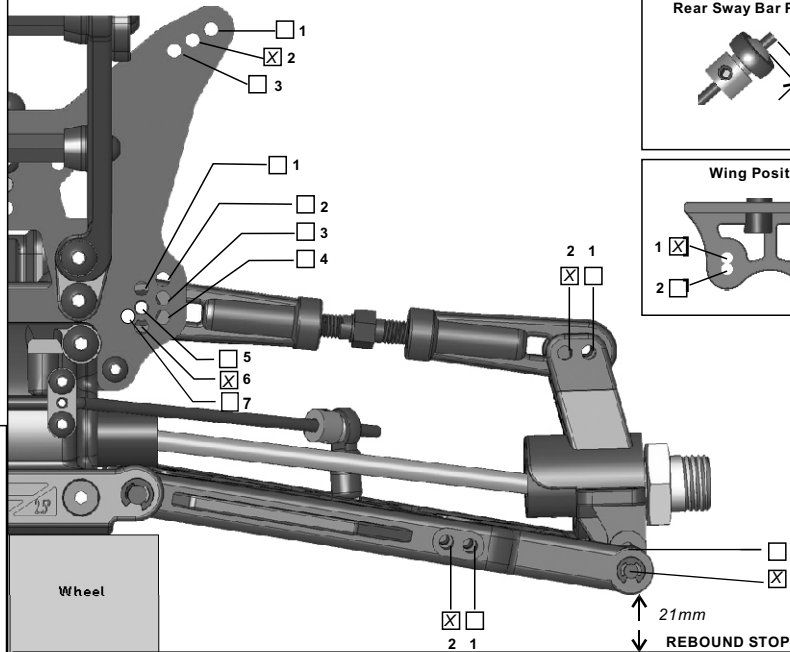
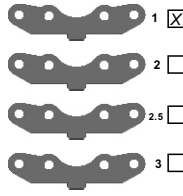
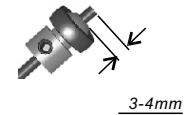
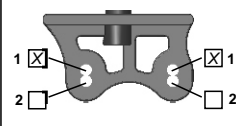
Rear Toe-In Plate

Anti-Squat Plate

Rear Sway Bar Preload

Wing Position

Notes: _____

Differentials

 Front Type: Standard Oil: 7,000

 Center Type: Standard Oil: 10,000

 Rear Type: Standard Oil: 3,000

Tires

 Front Type: P.L. Inside Jobs Compound: M3 Foam: Stock

 Rear Type: P.L. Inside Jobs Compound: M3 Foam: Stock

Note: _____

Engine

 Type: Trinity Sirio

 Head Clearance: Std. Pipe: Jammin JP-1

 Fuel: Trinity Platinum %30 Plug: OD 99

Needle (Top): _____ (Bottom): _____

Note: _____

Clutch

 Shoe Brand: Jammin X1-CR Stock Compound: Blue Aluminum

 Spring Brand: Jammin X1-CR Tension: X1-CR Stock 1.0mm Black

 Gearing: 13T 14T To 46T 48T

Note: _____