

Driver: Adam Drake

Track: The Farm 2 Fall Nitrofest

Air Temp: 65'sF

Surface Description: Red Clay Dry

Avg. Lap Time:

## Front Suspension

Shock Spring: Jammin Red

Shock Piston: Stock Big Bore

Shock Oil wt: 45 wt. Losi

Shock Length (Center to Center): N/A

Toe-IN:

Toe-Out: 1 degree

Front Ride Height: Front arms level

Sway Bar: 2.6mm

Camber: Neg: 2 degrees

Pos:

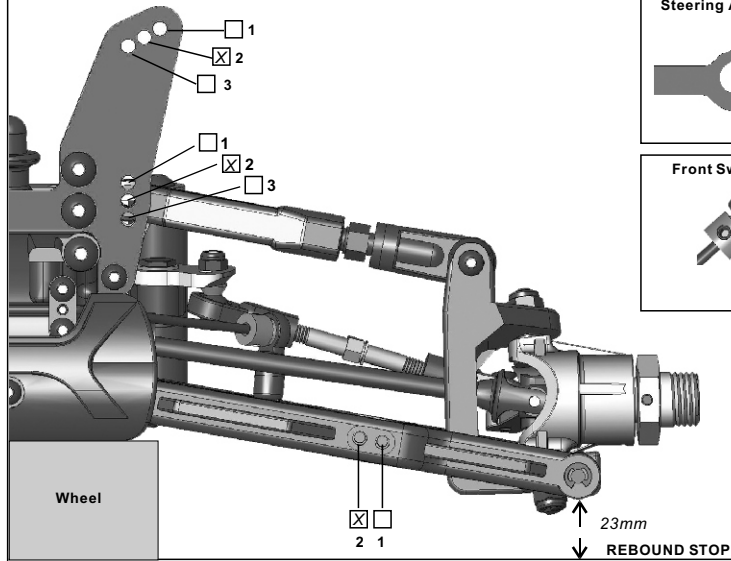
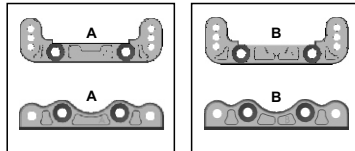
 Camber Block:  A/A  B/B

### Steering Ackerman Location



### Front Sway Bar Preload

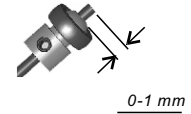

Notes:

## Rear Suspension

Shock Spring: Jammin Red

Shock Piston: Stock Big Bore

Shock Oil wt: 32.5 wt. Losi

Shock Length (Center to Center): N/A

Rear Ride Height: Arms parallel with ground

Sway Bar: 2.5mm

Camber: Neg: 2 degrees

Pos:

 Rear Hub/Wheelbase:  Forward  Middle  Back

### Rear Toe-In Plate

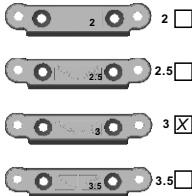

### Anti-Squat Plate

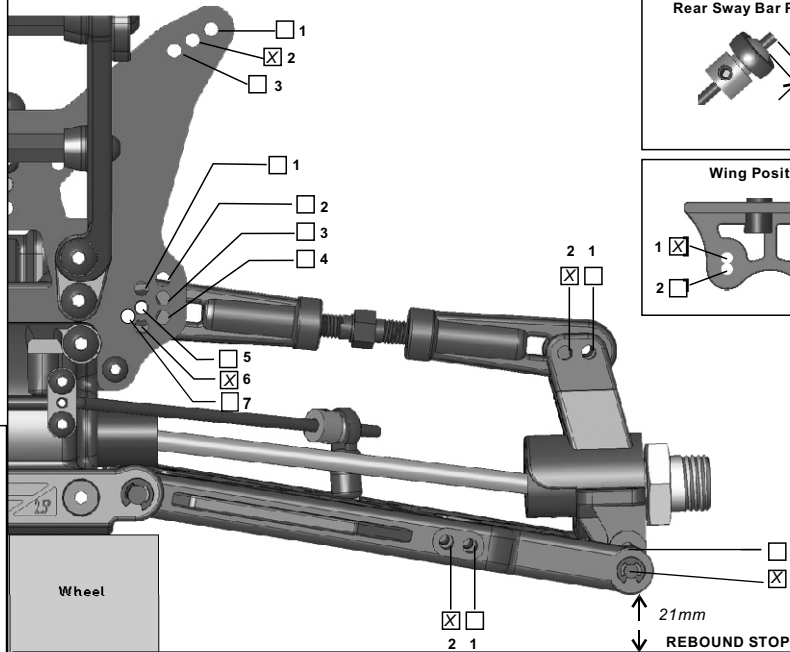
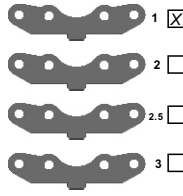

### Rear Sway Bar Preload

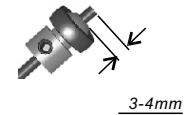

### Wing Position

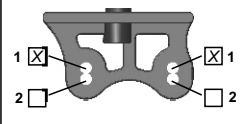

## Differentials

Front Type: Standard Oil: 5,000

Center Type: Standard Oil: 7,000

Rear Type: Standard Oil: 2,000

## Tires

Front Type: P.L. Crime Fighters Compound: M2 Foam: Stock

Rear Type: P.L. Crime Fighters Compound: M2 Foam: Stock

Note:

## Engine

Type: Trinity Sirio

Head Clearance: Std. Pipe: Jammin JP-1

Fuel: Trinity Platinum %30 Plug: OD 99

Needle (Top): (Bottom):

Note:

## Clutch

Shoe Brand: Jammin X1-CR Stock Compound: Blue Aluminum

Spring Brand: Jammin X1-CR Tension: X1-CR Stock 1.0mm Black

 Gearing:  13T  14T To  46T  48T

Note: